

# Interface-parameter meeting #2

Jun 28, 2011

**Kentaro Somiya**

*Tokyo Inst of Technology*

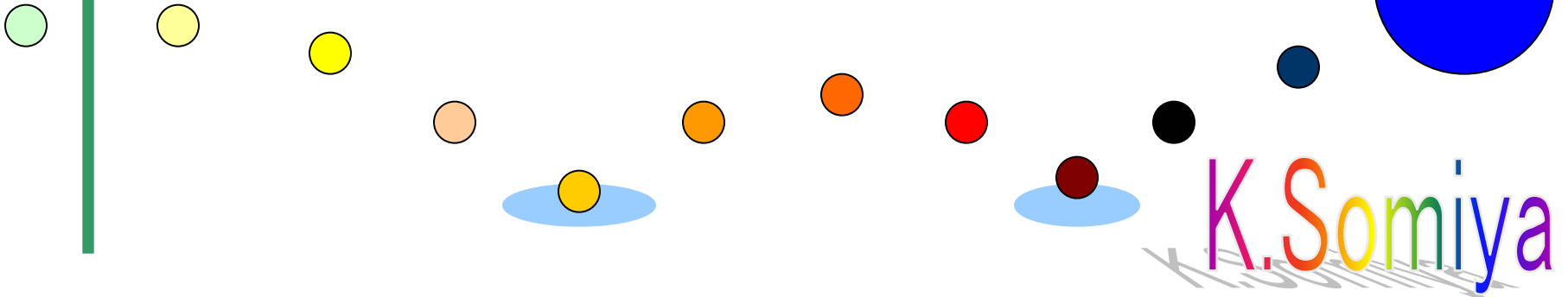

# Contents

1. 中間マス温度

2. 点状散乱と輻射シールド

3. RMS

4. 高次モードとOMC

5. Parameter list (cont'd from the last time)

重要そうなものを  
先にやっつけます

# 中間マス温度

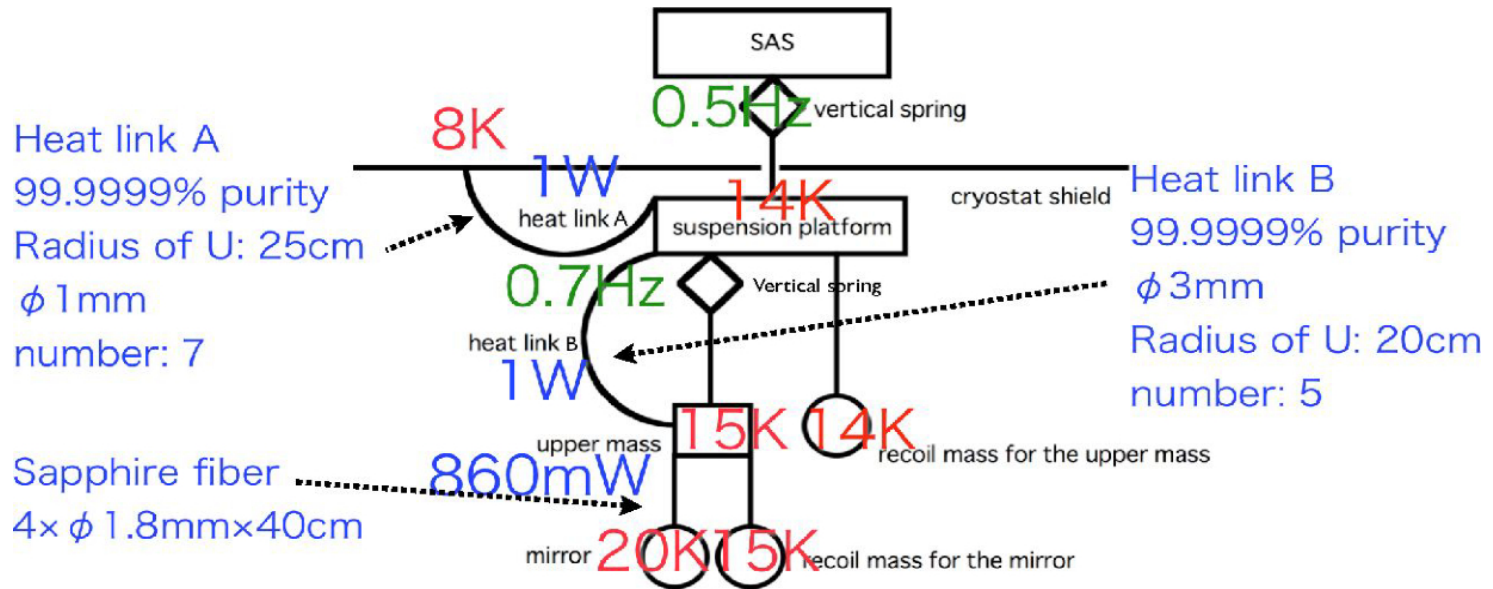

- 10K説と15K説が混在 (LCGT Documentでは10Kと書いてある)
- 10Kだと1Wの熱伝送が可能、15Kだと0.74W (まるめて1W)
- 中間マス以上が全て15Kを想定して設計されていた
- 10Kだとヒートリンクの数が増大し、現実的に厳しいby内山さん



15Kとする (熱吸収の要求値は厳しくなる)

安全係数はすでに2に満たない

# 点状散乱

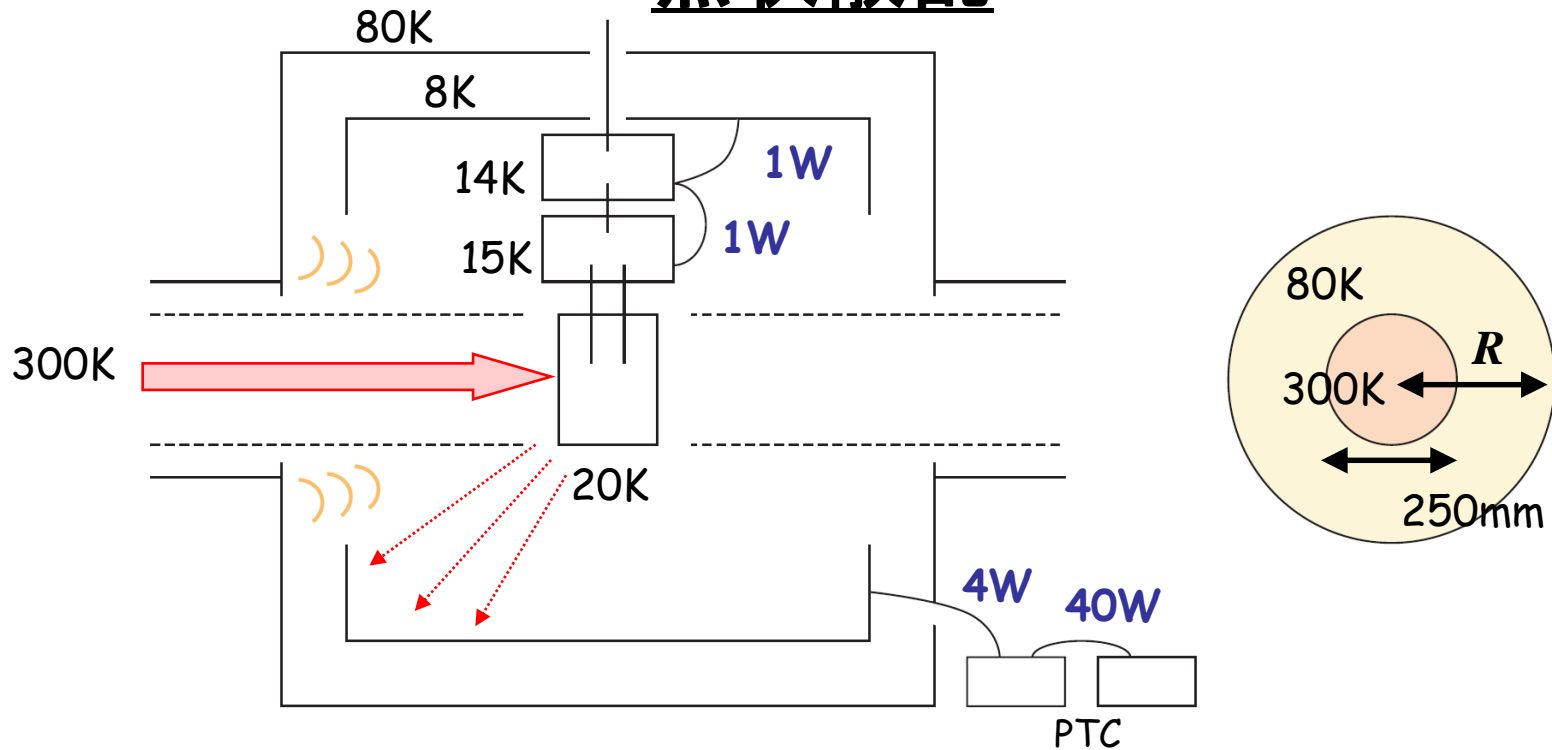

- 8Kの開口が狭いと点状散乱光が8Kシールドを加熱 (デフォルトでは $\phi 250$ )
- 8Kの開口が広いと80Kシールドからの熱放射が増大
- 光吸収が0.44W、15Kの中間マスへの熱伝送が0.74W→残り300mW
- 300Kの熱放射吸収は $28.7\text{mW} \times 2 \times 0.05 = 3\text{mW}$ 程度 (バツフルby榊原)

# 点状散乱

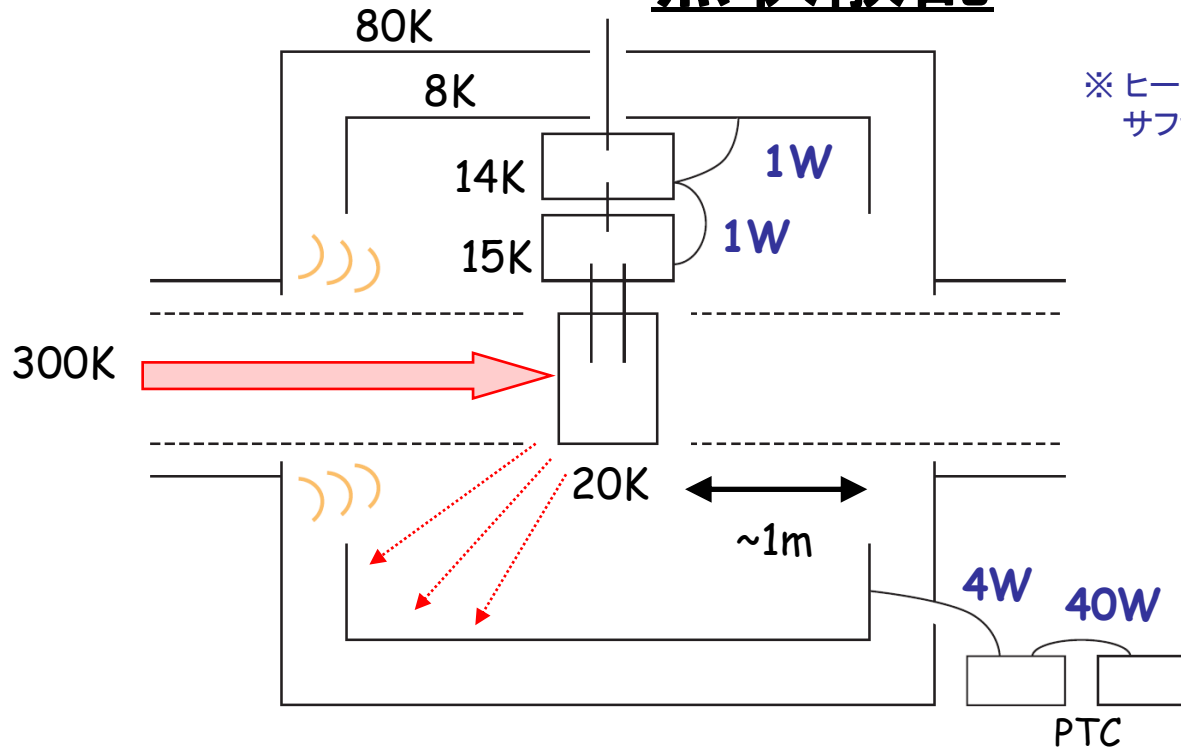

※ ヒートリンクの熱伝導率は8K付近でピーク  
 サファイアファイバーは30K付近でピークを示す

- 開口からの入熱 =  $0.05 \times 80^4 \times (R-0.125)^2 \times 3.14 \times 5.67e-8$   
 $\sim 0.365 \times R^2$  [W] → 吸熱 =  $0.0182 \times R^2$  [W]
  - 1ppmの点状散乱から8Kシールドへの入熱  
 $= 400kW \times 1ppm \times [1 - \text{atan}(R-0.125)^2] / [3.14/2]^2$   
 $\sim 0.162 \times (1-R^2)$  [W]
- ※ 8Wの入熱でIM温度が3度上昇する by 木村さん

# RMS

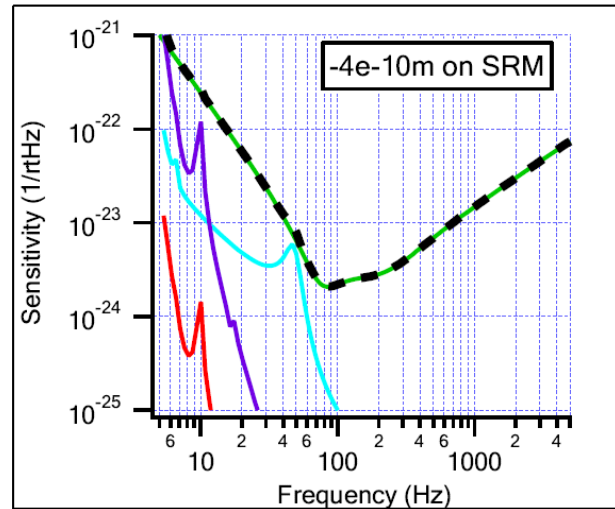
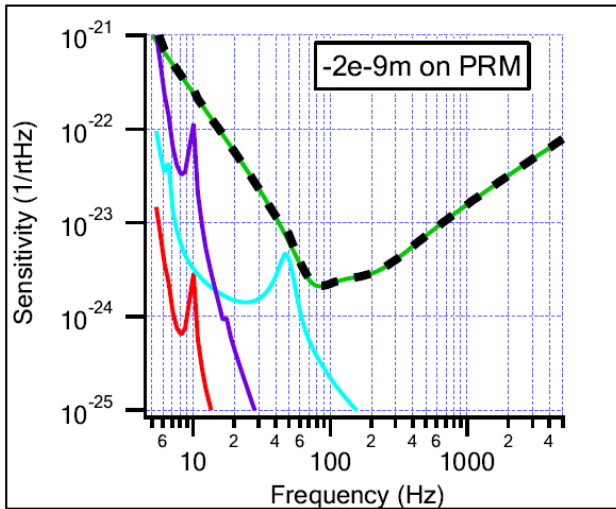
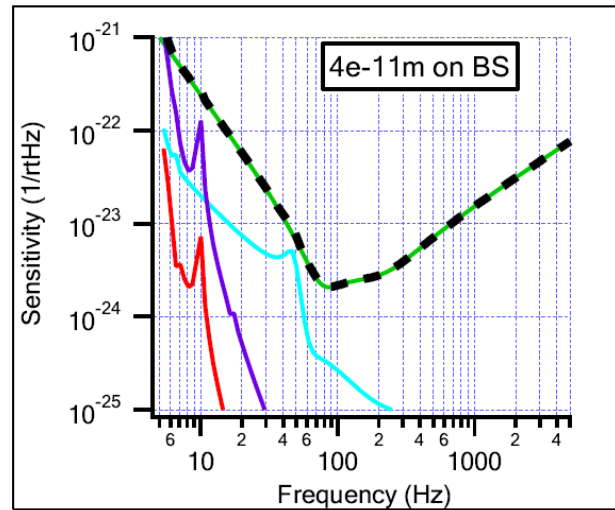
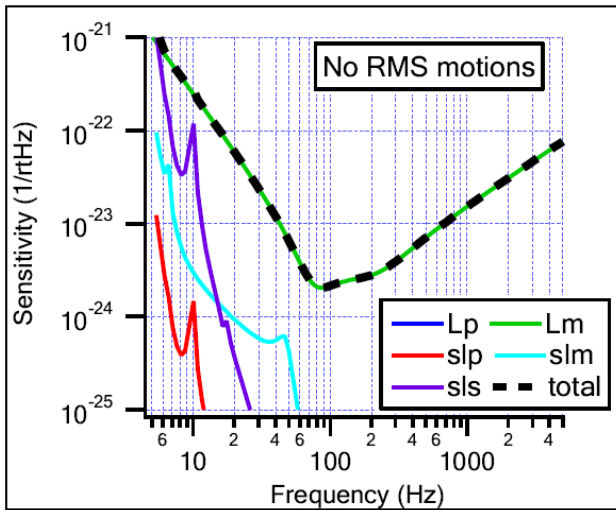

OMC

間に合いませんでした。

# インフラ

Facility	tunnel width/height	4m	TU	FA	VA		
Facility	tunnel tilt	1/300	TU	FA	VA		IF
Facility	chamber room size (2nd floor)	8m x 12m	TU	FA	VA		IF
Facility	chamber room size (1st floor)	20m x 12m	TU	FA	VA		CR IF
Facility	diameter of borehole for SAS	1.2m	TU	FA	VA	VI	
Facility	duct height from floor	1.2m from the floor		FA	VA		IF
Facility	duct diameter	80cm		FA	VA		IF
Facility	room temperature	290K		FA			
Cryostat	radiation shield diameter	50cm			VA		CR
Cryostat	radiation shield aperture (diameter)	25cm			VA		CR IF
Cryostat	top hole diameter (to SAS)	15cm			VA	VI	CR IF
Cryostat	heat from shield aperture	4W			VA		CR
Cryostat	heat from vacuum duct support	24W			VA		CR
Cryostat	radiation from upper stages	* 10mW			VA	VI	CR IF
Cryostat	radiation from BS chamber	60mW x 0.05			VA		CR IF
Cryostat	radiation from arm cavity	60mW x 0.05			VA		CR IF
Cryostat	heat from 80K radiation shield	* TBD			VA		CR IF
Cryostat	heat from point scattering light	* TBD			VA		CR IF
Cryostat	heat from view ports	0.4W x 0.05			VA		CR IF
Cryostat	heat link thermal conductivity at 10K	4kW/m/K				VI	CR
Cryostat	number of view ports	11			VA		CR IF
Cryostat	vibration at cryostat	5e-11m/rtHz(10Hz)	TU	FA	VA	VI	CR IF
Cryostat	inner shield temperature	8K			VA	VI	CR IF
Cryostat	duct shield temperature	80K			VA	VI	CR IF



# インフラ(図)

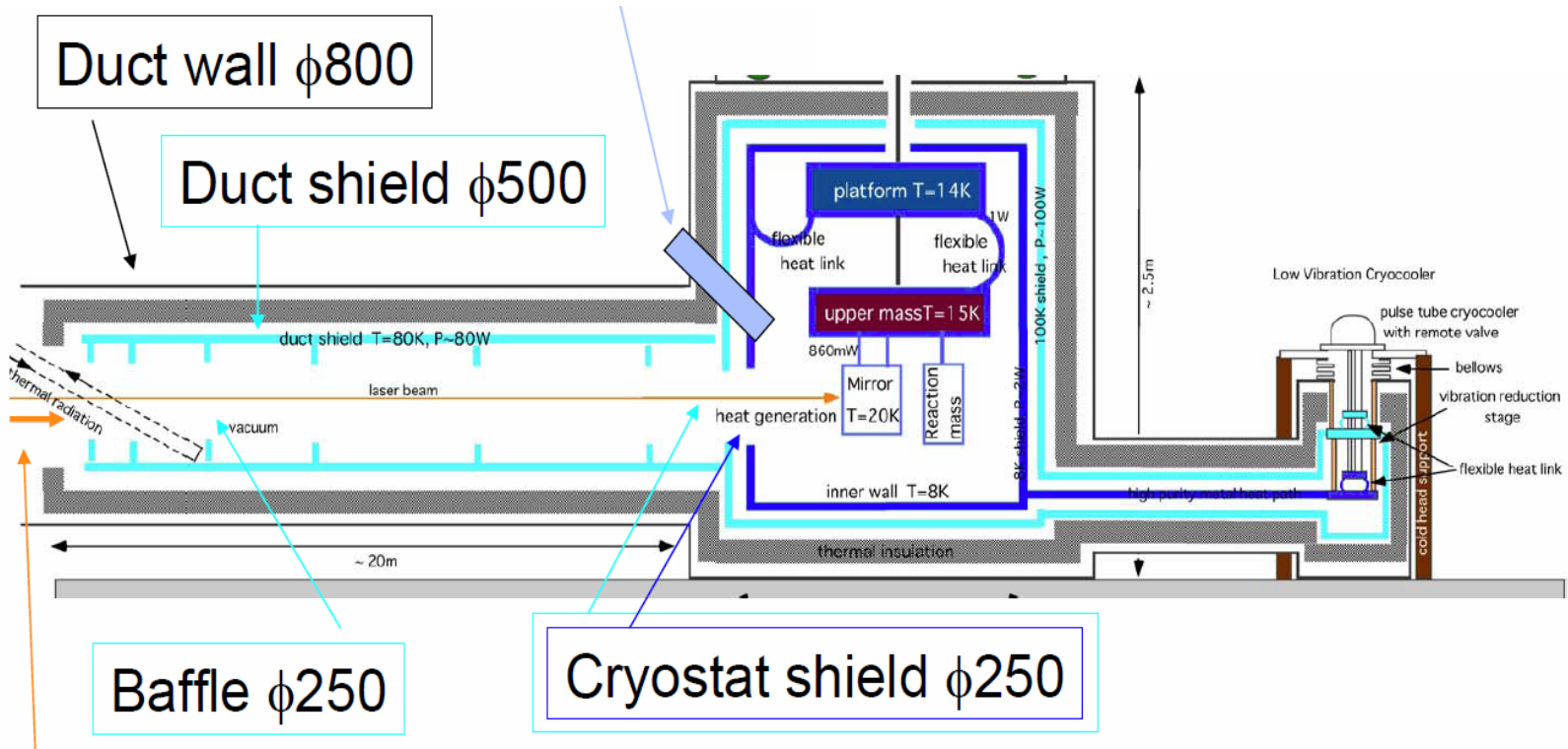

Position of baffles $x$ [m]	$P/P_0$	$P$ [mW]
0,20	0.0487	110
0,4,20	0.0359	81.0
0,5,10,15,20	0.0199	44.9
0,3,10,15,20	0.0127	<b>28.7</b>

$$P_0 = \epsilon \sigma T^4 A = 2.25 \text{ W}$$

$\epsilon = 0.1$ : Emissivity of duct (SUS)

$\sigma$ : Stefan-Boltzmann constant

$T = 300 \text{ K}$

$A$ : Area of opening

# 光学系1

Laser	laser power	180W				IF		IO	LA
Laser	free-run frequency noise	100Hz/rtHz at 100Hz				IF		IO	LA
Laser	free-run intensity noise	1e-4 W/W/rtHz				IF		IO	LA
PMC	cavity length	* 48.8cm						IO	
PMC	finesse	* 155						IO	
IOO	AF RIN (requirement)	TBD				IF		IO	LA
IOO	RF RIN (requirement; f>15MHz)	1e-9W/W/rtHz				IF		IO	LA
IOO	FSS gain at 100Hz	300dB				IF	EL	IO	LA
IOO	FSS gain at 1kHz	180dB				IF	EL	IO	
IOO	pick-off power for FSS	100mW					EL	IO	
IOO	COF between EOM and PZT	TBD				IF		IO	LA
IOO	COF between PZT and MC length	TBD				IF		IO	LA
IOO	COF between MC length and thermal	TBD				IF		IO	LA
IOO	RF oscillator phase noise	-160dBc				IF		IO	
IOO	power attenuation range	100%-0.1%				IF		IO	
IOO	extinction ratio of Faraday Isolator	40dB				IF		IO	
MC2	MC-in and MC-out RoC	* >500km			MI	IF		IO	
MC2	MC-end RoC	40m			MI	IF		IO	
MC2	MC mirror dimension	f100mm, t30mm			MI	IF		IO	
MC2	distance of MC-in and MC-out	0.5m				IF		IO	
MC2	beam radius on MC-end	4.377m				IF		IO	
MC2	beam radius on MC-in and MC-out	2.527m				IF		IO	
MC2	MC-end reflectivity	99.99%				IF		IO	
MC2	MC-in and MC-out reflectivity	99.37%			MI	IF		IO	
MC2	MC finesse	500			MI	IF		IO	
MC2	output polarization	S-polarization		VA	MI	IF		IO	
MMT	MMT mirror dimension	f100mm, t30mm			MI			IO	
MMT	MMT1 RoC	20.6m			MI			IO	
MMT	MMT2 RoC	26.1m			MI			IO	
PRM (SRM)	PM1 radius	12.5cm			VI	MI			
PRM (SRM)	PM1 thickness	10cm			VI	MI			
PRM (SRM)	PM2 radius	12.5cm			VI	MI			
PRM (SRM)	PM2 thickness	10cm			VI	MI			
PRM (SRM)	PM3 radius	12.5cm			VI	MI			
PRM (SRM)	PM3 thickness	10cm			VI	MI			
PRM (SRM)	PRM/SRM reflectivity	90%/85%			MI	IF			
PRM (SRM)	PRM optical loss	100ppm			MI	IF			

# 光学系(图)

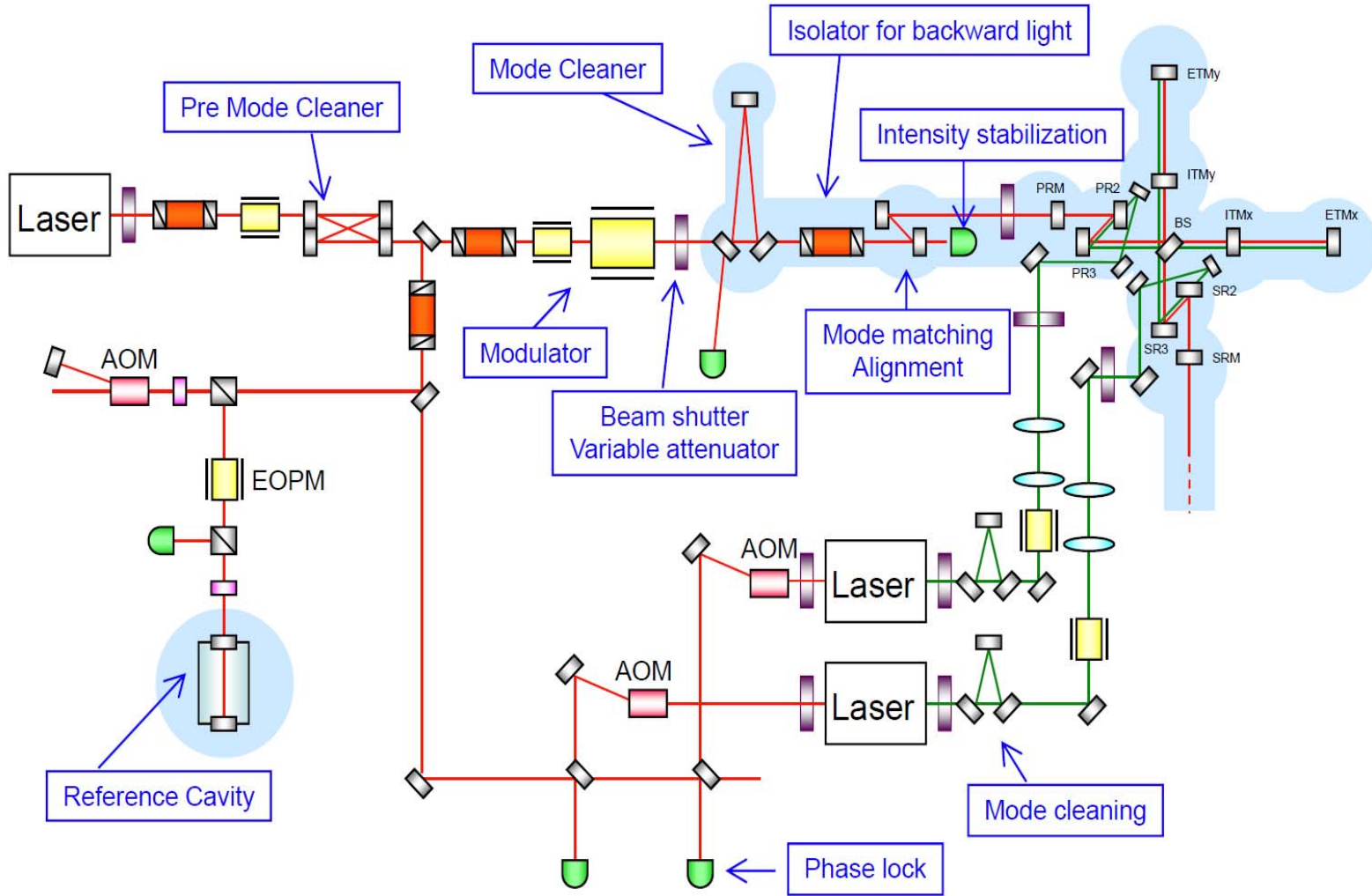

# 光学系2

前回やった  
のはこの辺  
くらいまで



PRM (SRM)	RoC of PRM	370m
PRM (SRM)	RoC of PR2	4.17m
PRM (SRM)	RoC of PR3	32.34m
PRM (SRM)	RoC error of PRM	1%
PRM (SRM)	RoC error of PR2	1%
PRM (SRM)	RoC error of PR3	1%
PRM (SRM)	wedge angle of PRM (horizontal)	* 0.3deg
BS	BS radius	19cm
BS	BS thickness	12cm
BS	BS HR surface optical loss	50ppm
BS	BS AR surface reflectivity	50ppm
BS	RoC of BS	>500km
BS	BS absorption	* 1.5ppm/cm
BS	AR wedge of BS	0.383deg
BS	AR wedge error of BS	2.5%
BS	SAS motion range for compensation	+/-1cm
TM	dimension	f250 x t150
TM	temperature	20K
TM	Outer Diameter	25cm
TM	Outer Diameter Flat to Flat	* 24.6cm
TM	local actuator of TM	ESD
TM	RRR of material	TBD
TM	central region surface rms	0.3nm (d<12cm)
TM	outer region surface rms	* 1nm (d>12cm)
TM	beam radius on ETM	4.53cm
TM	beam radius on ITM	3.43cm
TM	mirror mechanical loss of ETM	1e-8
TM	mirror mechanical loss of ITM	1e-8
TM	silica coating loss	3e-4
TM	tantala coating loss	5e-4
TM	number of layers on ETM	18
TM	number of layers on ITM	9
TM	coating absorption	0.5ppm
TM	AR surface absorption	1ppm
TM	ETM reflectivity	0.999945
TM	ITM reflectivity	0.996
TM	ETM optical loss	45ppm

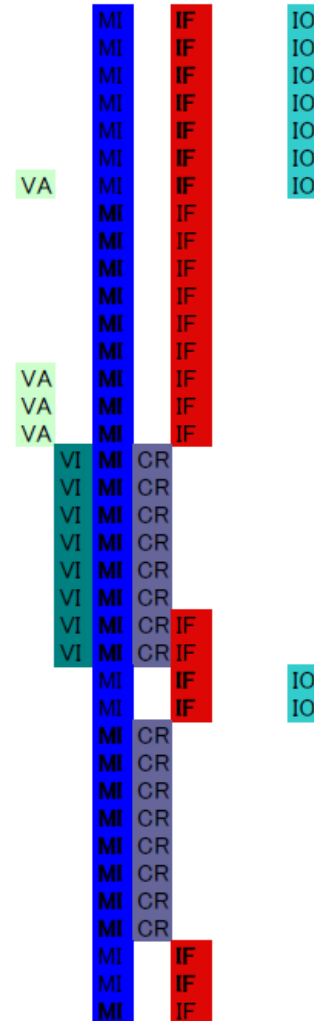

# 光学系3

TM	ITM optical loss	45ppm		MI	IF	
TM	optical loss imbalance	+/-15ppm		MI	IF	
TM	finesse imbalance	0.5%		MI	IF	
TM	ITM substrate optical loss	20ppm/cm		MI	IF	
TM	ITM AR surface optical loss	* 1000ppm		MI	IF	
TM	ETM mass	30kg		MI	IF	
TM	ITM mass	30kg		MI	IF	
TM	RoC error of ETM	* 1%		MI	IF	
TM	RoC error of ITM	* 1%		MI	IF	
TM	RoC of ETM	7km		MI	IF	
TM	RoC of ITM	>500km		MI	IF	
TM	RoC imbalance in two arms	* 0.5%		MI	IF	
TM	wedge angle of ETM	* 0.3deg	VA	MI	IF	
TM	wedge angle of ITM	* 0.3deg	VA	MI	IF	
TM	wedge angle error of TMs	TBD	VA	MI	IF	
OMC	OMC optical loss	* 1%		MI	IF	IO
OMC	OMC length	* 38cm	VA		IF	IO
OMC	OMC finesse	* 1000 (too high for 1% loss)			IF	IO
OMC	RF reduction ratio	110dB			IF	IO
MIF	(laser power in PRC)	825W			IF	IO
MIF	(total optical loss in SRC)	2%		MI	IF	IO
MIF	quantum efficiency (DC PD)	90%			IF	EL
MIF	differential offset on arm cavities	+/- 2e-12m			IF	IO
MIF	detune phase	3.55deg			IF	
MIF	folding angle	0.6293deg	VA		IF	
MIF	f1 PM/AM sideband frequencies	16.875MHz			IF	IO
MIF	f1 modulation depths (PM)	* 0.2 at IFO			IF	IO
MIF	f2 PM sideband frequencies	45MHz			IF	IO
MIF	f2 modulation depths	* 0.2 at IFO			IF	IO
MIF	f3 AM sideband freq (if any)	39.375MHz			IF	EL
MIF	f3 modulation depths (if any)	TBD			IF	IO
MIF	MZ configuration	single, if any			IF	IO
MIF	Beam centering error on TM	* 0.1mm		VI	IF	
MIF	CARM UGF	10kHz		VI	IF	EL
MIF	DARM UGF	200Hz		VI	IF	EL
MIF	PRCL UGF	20Hz		VI	IF	EL
MIF	MICH UGF	20Hz		VI	IF	EL

# 光学系4

MIF	SRCL UGF	20Hz
MIF	PRCL/MICH/SRCL FF gain	100
MIF	Green Laser finesse in arms	19 (ITM80%-ETM90%)
MIF	Green Laser power	100mW
MIF	Green laser's frequency gap (X and Y)	100MHz
MIF	Green laser Injection Point	PR3 and SR3
MIF	BS reflectivity for green	<1%
MIF	PR2, SR2 reflectivity for green	<1%
MIF	PR3, SR3 reflectivity for green	>99%
MIF	rms fluctuation of DARM	1e-14m

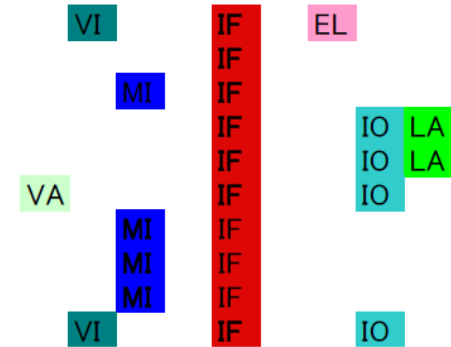

# 懸架系

4th GAS	T dependence of spring constant	TBD
HL (Sh-PF)	radius of U	25cm
HL (Sh-PF)	diameter	1mm
HL (PF-IM)	radius of U	20cm
HL (PF-IM)	diameter	3mm
HL (PF-IM)	loss	5e-5
IM	temperature of IM	15K
IM	emmissivity of surface of IM	* 0.02
IM fiber	loss	1e-4
IM fiber	length	0.4m
IM fiber	diameter	0.72mm
IM fiber	temperature	15K
RM	mass of RMTM	30kg
RM	material of RMTM	Cu
RM	outer diameter	29cm
RM	inner diameter	26cm
RM	thickness	26cm
RM	temperature of RMTM	* 20K
RM fiber	length	30cm
RM fiber	diameter	0.4mm
RM fiber	loss	5e-6
TM fiber	length	30cm
TM fiber	diameter	1.6mm
TM fiber	effective temperature	* 16
TM fiber	loss	2e-7
SAS	Vertical horizontal coupling	1/200

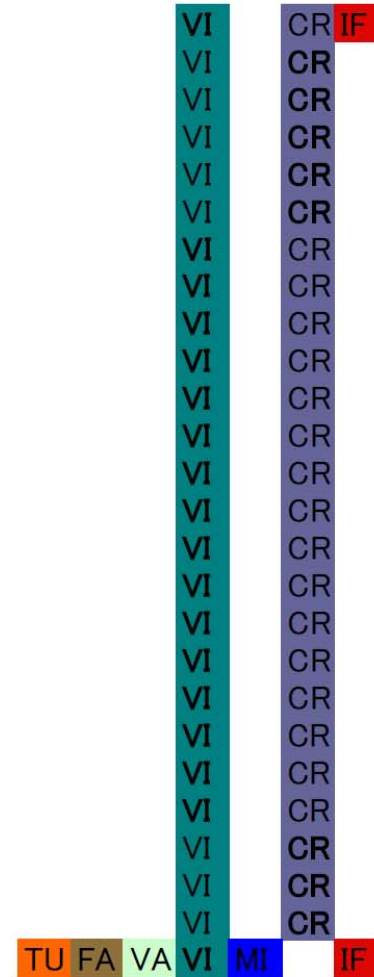

# 懸架系(図)

## Modeling for displacement

### Type-A

- Equation of motion of 10 material points model
- 10x10 stiffness matrix
- 2-layer structure
- Calculated by MATLAB

	m	Q	f0	C
	[kg]		[Hz]	[kg·Hz]
Filter0	120	5	0.03	-
Filter1	90	5	0.34	-
Filter2	90	10	0.34	-
Filter3	90	10	0.34	-
CB	60	10	0.35	376
PF	60	100	0.5	376
IM	60	1000	0.7	530
MB	60	1000	0.7	530
TM	30	1000	0.8	-
RM	30	6	0.8	-

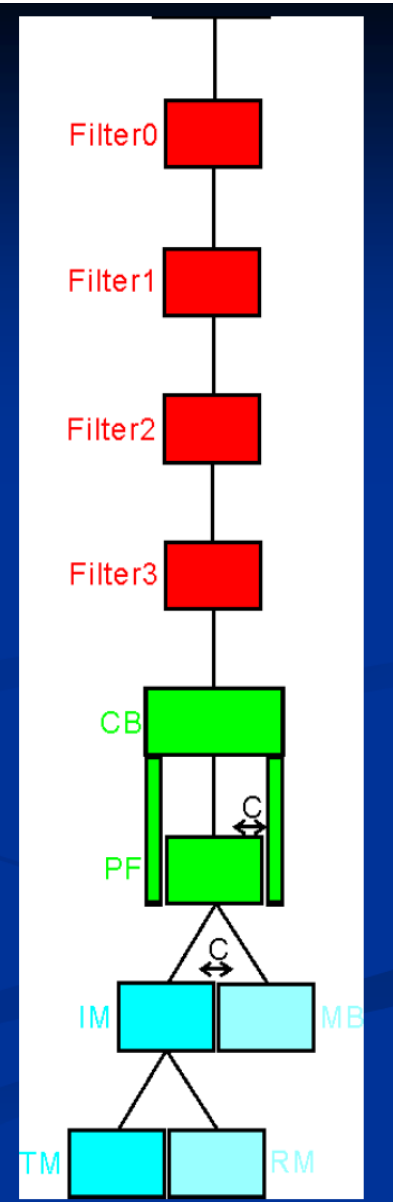



# 電気系少々

Electronics	PD aperture	* 3mm
Electronics	RF PD input power (high power)	* 300mW
Electronics	RF PD input power (low power)	* 100mW
Electronics	DC PD input power (high power)	* 100mW
Electronics	DC PD input power (low power)	* 10mW

IF	EL
IF	EL
IF	EL
IF	EL
IF	EL

- PD入力パワーはループ雑音の計算に関わってくる

以上です