

Layout 会議

2011/6/16
ICRR UT • EVO

Layout 会議の目的

- ① 干渉計メインビームの軸を決める(I,bLCGT共通)
 - MC→(FAI, MTR1, MTR2) →(PRM, PR1, PR2)
→BS→ITMs →ETMs
 - BS →SR2 →SR1 →SRM → MTSs
 - 鏡の位置 (鏡の厚みの情報がない) と径 (鏡の曲率) とウエッジ角
 - ② 決まったら、補助光学系への受け渡し光学系の配置を議論する
 - GIMs(Guide), BDPs(Beam Damping)
 - ③ そこから先はサブグループ・各補助光学系グループ内で決める
- ①は、ほとんどもう決まっているように見えるが一部問題もある。
②と、③のAOSから逆に入る光学系のルートや鏡、必要なら追加真空タンクの位置の確認が必要。

Layout Image by Ohmae

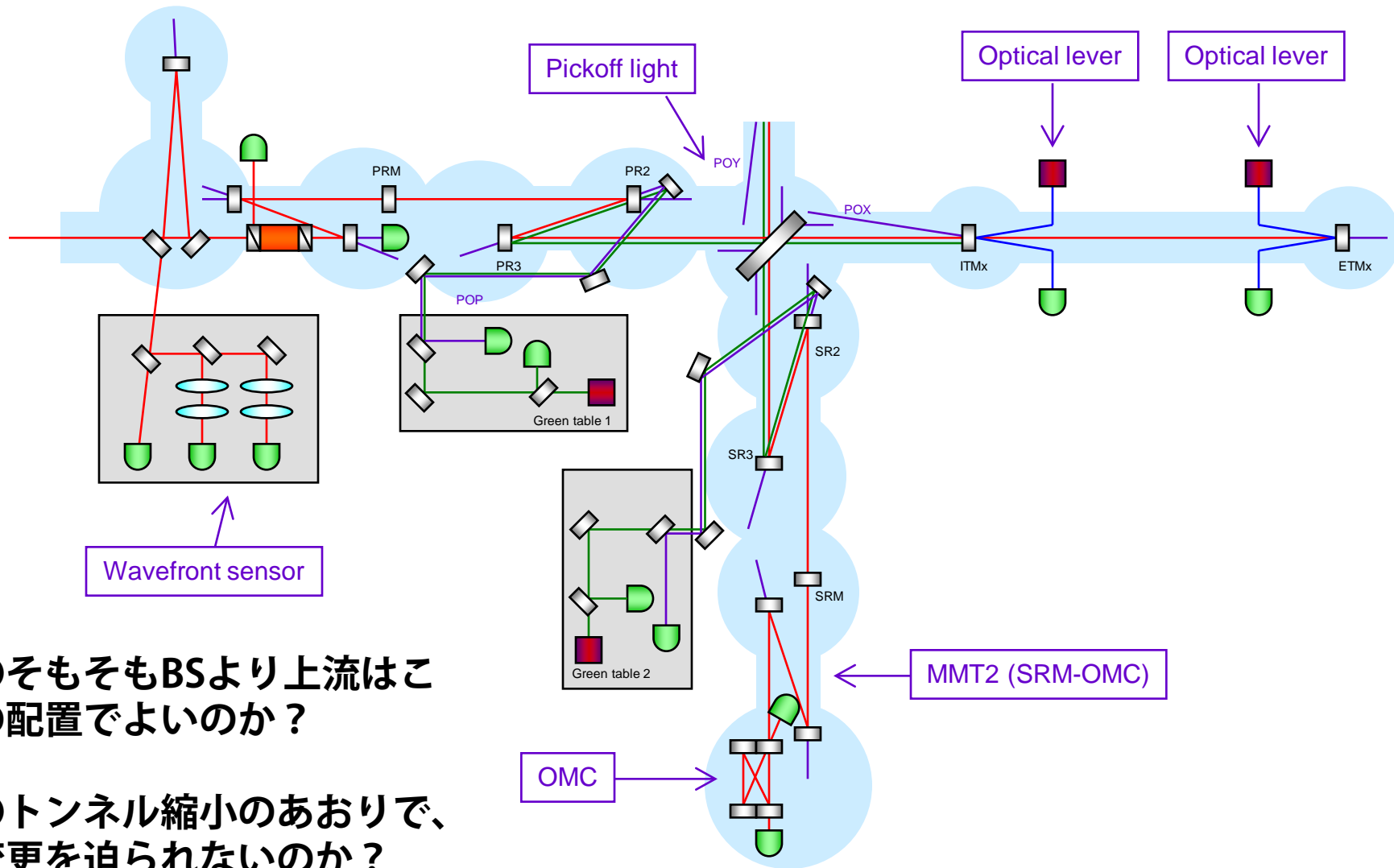

●そもそもBSより上流はこの配置でよいのか？

●トンネル縮小のあおりで、変更を迫られないのか？

MC光軸

① MC

- 共振器長 (←要求安定度・MIF RF・DCRO制御透過周波数)
- ビーム径: (←ダメージ閾値) → 鏡の最低コート面積
- 短軸位置と長さ (→正確なMC End Tankの位置に影響)
- 鏡厚とウェッジ (?)

② AOS for MC

- GIM and DAP
for
MCIn Ref, MCOt Ref,
MCEd Tra, AR, Window

直接外に出すか？
GIMを使うか？
真空外でよいか？

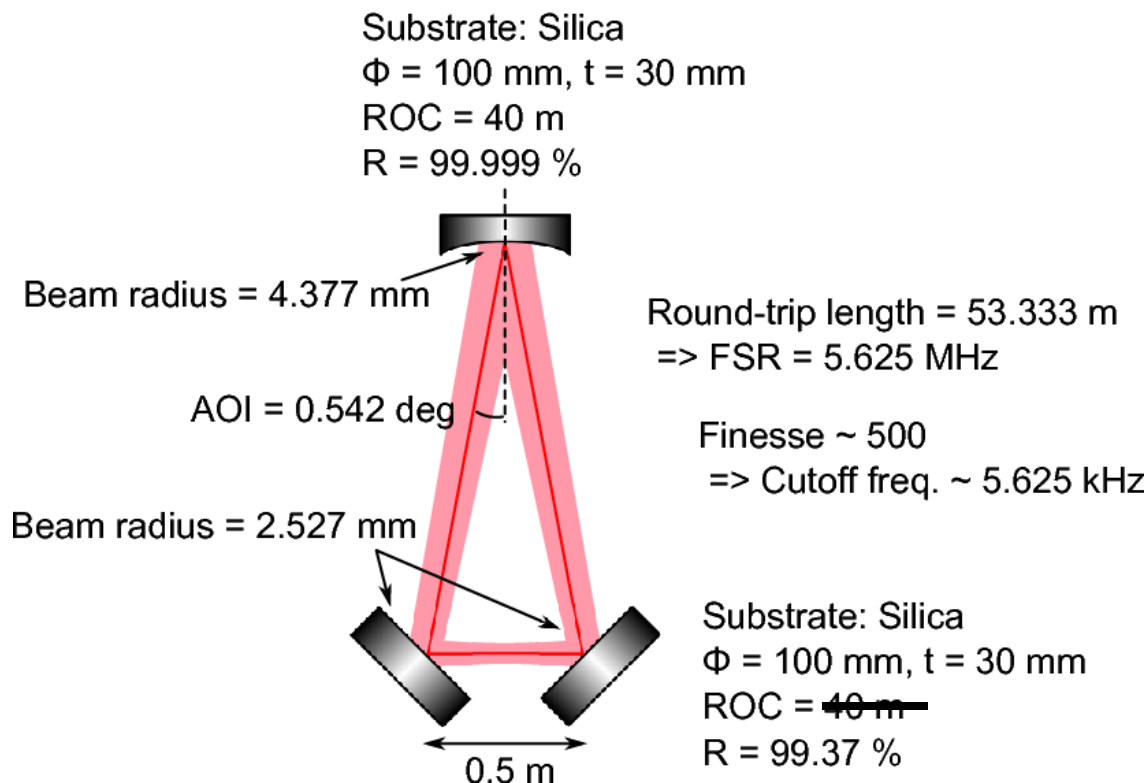

By ohmae

MTR光軸 (1)

① FAI, MTR1, MTR2

- 懸架装置の大きさにもよるが、原案だと無理がある？ MCは独立させるべき。
- FAIとMTR2を置く位置の確保→別タンクの内意
- FAIでの熱レンズ効果の考慮や強力な磁石の影響回避が必要
- MTRs間隔と曲率 (自由度多いby寺田君)
 - (←位置に鈍感な組み合わせがあるか)
 - (←ビーム径情報@PRM and MCout)
- MTRs ウェッジ(?)
- 平行ビーム間隔(?)

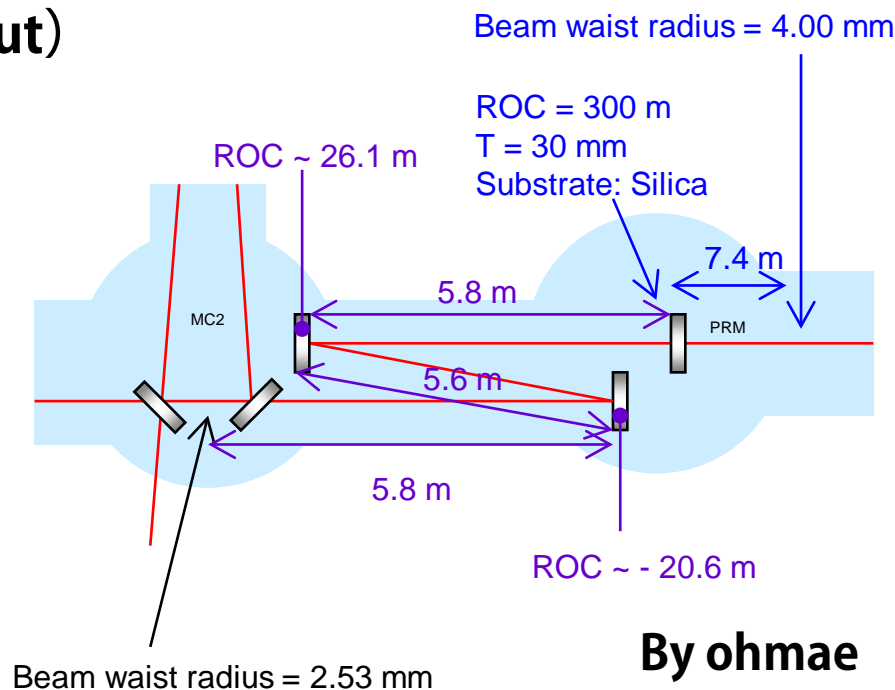
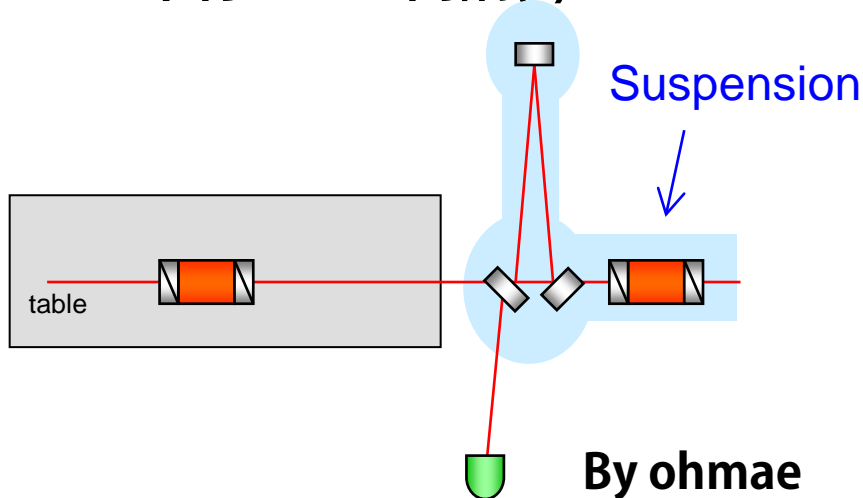

MTR光軸 (2)

② AOS for FAI, MTR1, MTR2

- GIM and BDP for Pick Off of FAI Input-Output PBS
- GIM and BDP for MTR1, MTR2 Trans and AR Ref
- Window Ref

MCを1~2m Laser側に動かす (掘削穴に収まる)

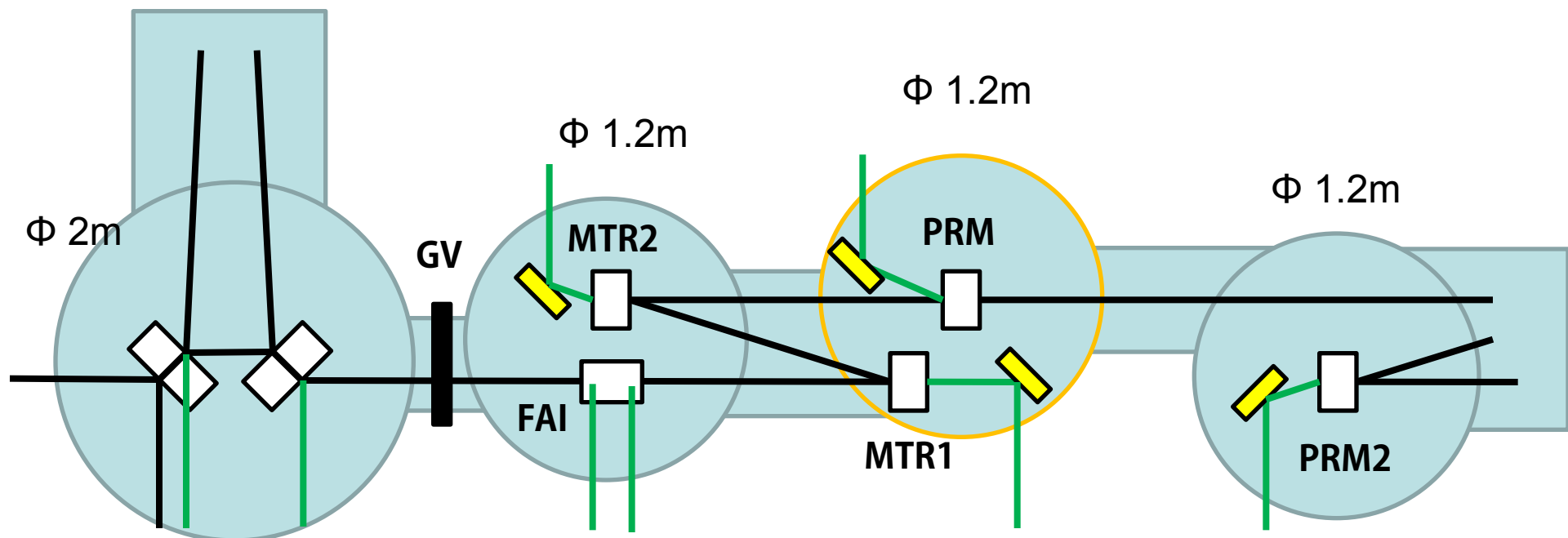

PRC光軸 (1)

① PRM, PR1, PR2, BS

- 共振器長 (←FP Cavity, ROC許容誤差, PI Stability, BS-ITM長,)
- ビーム径 (←ダメージ閾値)
- 入射角度 (←要求ビーム真円度, 高次モードカップル)
- 平行ビーム間隔 (0.629度だとPR1, PR2間隔が~26cm)
- 位置 (←ITMウエッジ角, BSのウエッジ角度, 鏡の厚み)

今の配置の若干の不安点：

BSに入射する最後のPR2鏡が、BSから遠い位置にある。つまり、ウエッジによる、シフト量が大きい。

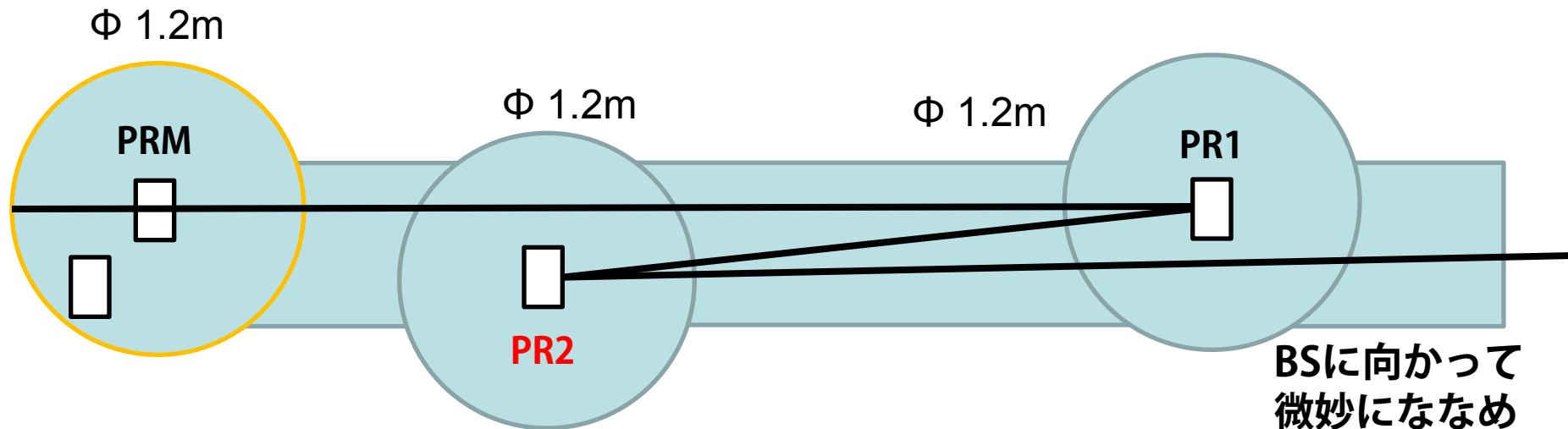

PRC光軸 (2)

① AOS for PRM, PR1, PR2

- GIM and BDP for PRM AR ref, PRM HR ref,
- GIM and BDP for PR1, PR2 Tra, AR Ref,
- Window Ref
- Green Locking Laser Introduction

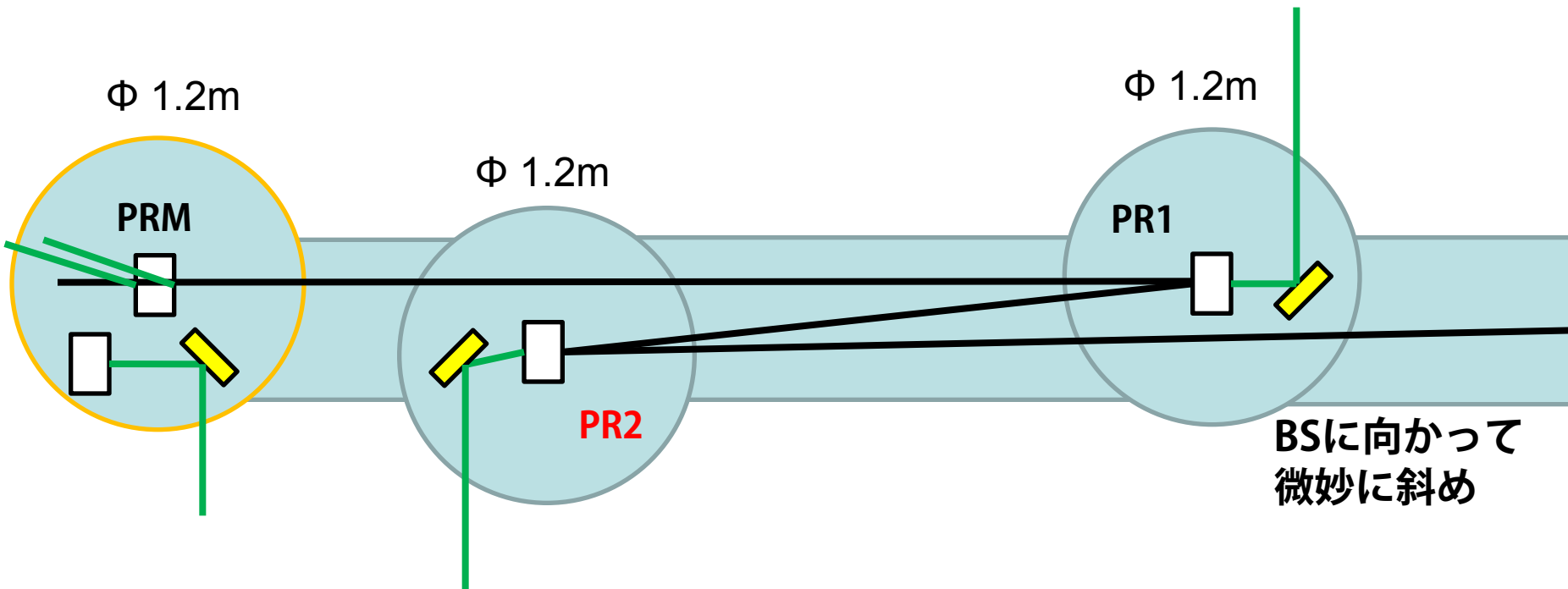

PRC光軸 Parameters

MIF_Design_Aso20110228

Parameter Name	Value	Comments
HR Reflectivity@1064 nm	90+0/-0.1%	
HR Loss@1064 nm	<100 ppm	
AR Reflectivity@1064 nm	<100 ppm	
HR ROC	300.6±1 m	
AR ROC	>100 km	As large as possible
AR Wedge Angle	2.0±0.1 deg	

Table 1.4: PRM Requirements

Parameter Name	Value	Comments
HR Reflectivity@1064 nm	99.95±0.01%	
HR Reflectivity@532 nm	<10%	As small as possible
HR Loss@1064 nm	<100 ppm	
HR Loss@532 nm	<1%	
AR Reflectivity@1064 nm	<500 ppm	
AR Reflectivity@532 nm	<10%	
HR ROC	-3.251±0.01 m	
AR ROC	>50 km	As large as possible
AR Wedge Angle	2.0±0.1 deg	

Table 1.6: PR2 Requirements

Parameter Name	Value	Comments
HR Reflectivity@1064 nm	>99.99%	
HR Reflectivity@532 nm	>80%	As large as possible
HR Loss@1064 nm	<100 ppm	
HR Loss@532 nm	<1%	
AR Reflectivity@1064 nm	<1000 ppm	
AR Reflectivity@532 nm	No requirement	
HR ROC	27.36±0.1 m	
AR ROC	>10 km	As large as possible
AR Wedge Angle	2.0±0.1 deg	

Table 1.7: PR3 Requirements

f1	16.880962 MHz	$3 \times f_{MC}$, PM
f2	45.015898 MHz	$8 \times f_{MC}$, PM
f3	39.388910 MHz and 56.269873 MHz	$7 \times f_{MC}$ and $10 \times f_{MC}$, AM
f_{MC}	5.626987 MHz	MC FSR
L_{MC}	26.6388 m	MC Length

Table 1.19: RF Sideband Frequencies

Parameter Name	Value	Comments
Lp1	14.761 m	Distance between PRM and PR2
Lp2	12.067 m	Distance between PR2 and PR3
Lp3	14.764 m	Distance between PR3 and BS
Ls1	14.761 m	Distance between SRM and SR2
Ls2	12.067 m	Distance between SR2 and SR3
Ls3	14.764 m	Distance between SR3 and BS
Folding Angle	0.6293 deg	The incident angle to the folding mirrors.

Table 1.18: Folding parameters. See Figure 1.2 for the meaning of the parameters.

332.8 by Agatsuma Report

BS

① BS

- (BS center or BS Ref Center) = Tank Center ??
- ITMのウェッジを考慮したビーム反射方向 (→GVの穴との整合性)
- BSの基材屈折率、ウェッジを考慮したビーム直進方向 (→GVの穴との整合性)
- BSの厚み
- ITMのウェッジ方向は、
対称配置？非対称配置？

② AOS around BS

- GIM for BS AR Refs
- GIM for ITM AR Ref
(どこに戻ってくる??)
(BS側のRadiation Shield
の切れ込みの指示が必要)
- Window Ref

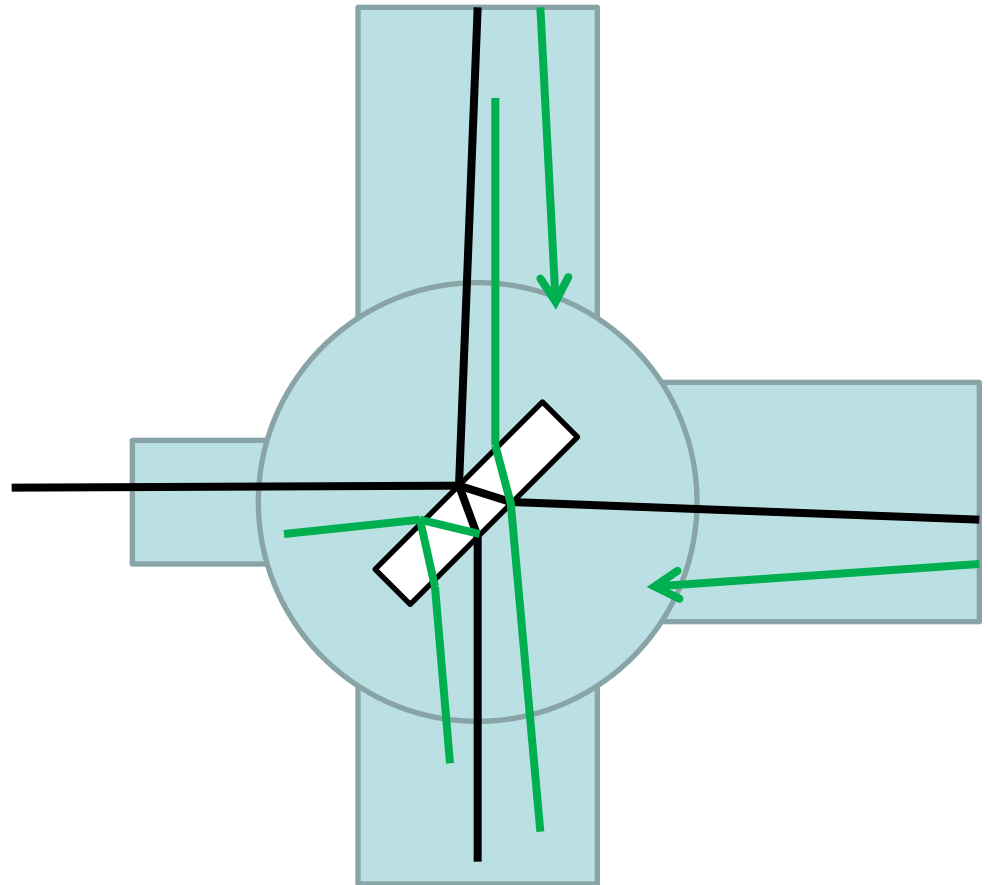

BS Parameters

MIF_Design_Aso20110228

Parameter Name	Value	Comments
HR Reflectivity@1064 nm	$50 \pm 0.5\%$	S Polarization
HR Reflectivity@532 nm	$< 10\%$	As small as possible
AR Reflectivity@1064 nm	< 50 ppm	
AR Reflectivity@532 nm	$< 10\%$	
HR ROC	> 500 km	As large as possible
AR ROC	> 500 km	As large as possible
AR Wedge Angle	0.383 ± 0.002 deg	

Table 1.3: Beam Splitter Requirements

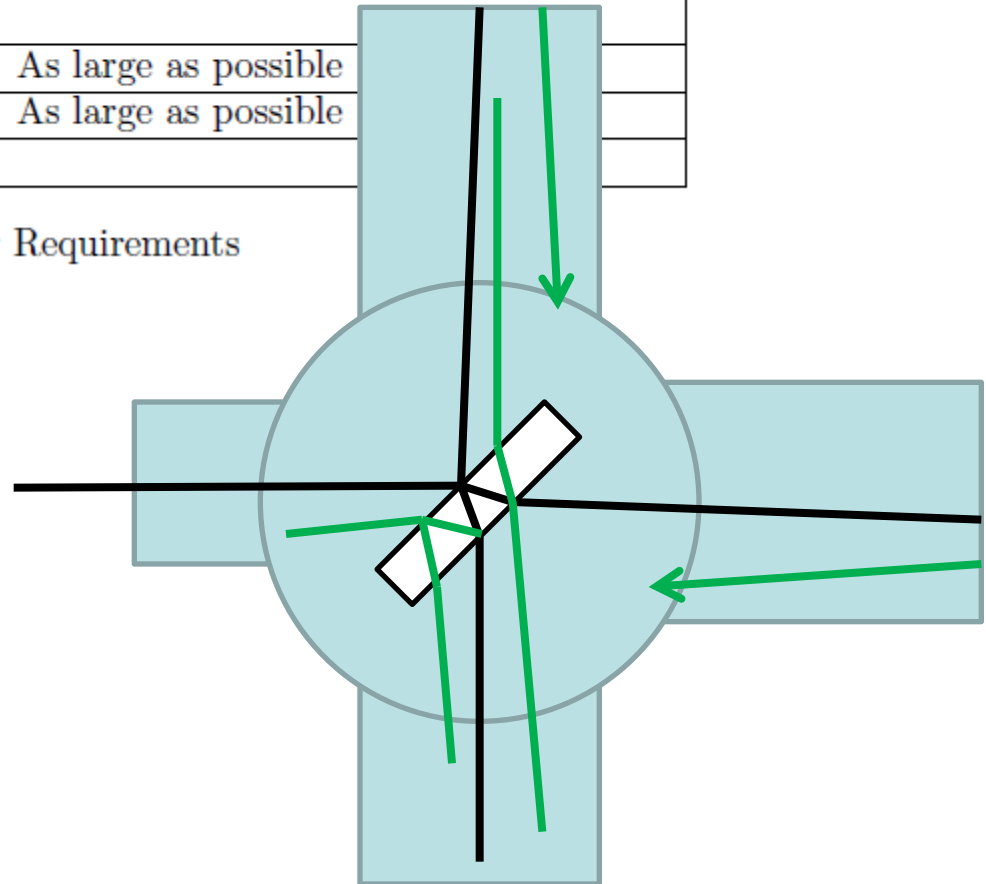

ITM

① ITM

- (ITM center or ITM HR Center) = Tank Center ??
- ITMのウエッジを考慮したビーム入射方向
(→ Radiation DuctはITM-BSの横ずれを考慮して斜めにつける。斜めでない場合は、バツフル穴の位置に注意。)
- BS側GVの穴の位置に注意 (GVの取り付け方に依存) 。

② AOS around ITM

- GIM for ITM AR Refs in BS Tank
(→ BS側のRadiation Shieldの切れ込みの指示が必要?)
- Optical Crank and CCD monitor Tank from Arm Side
- Windows Ref

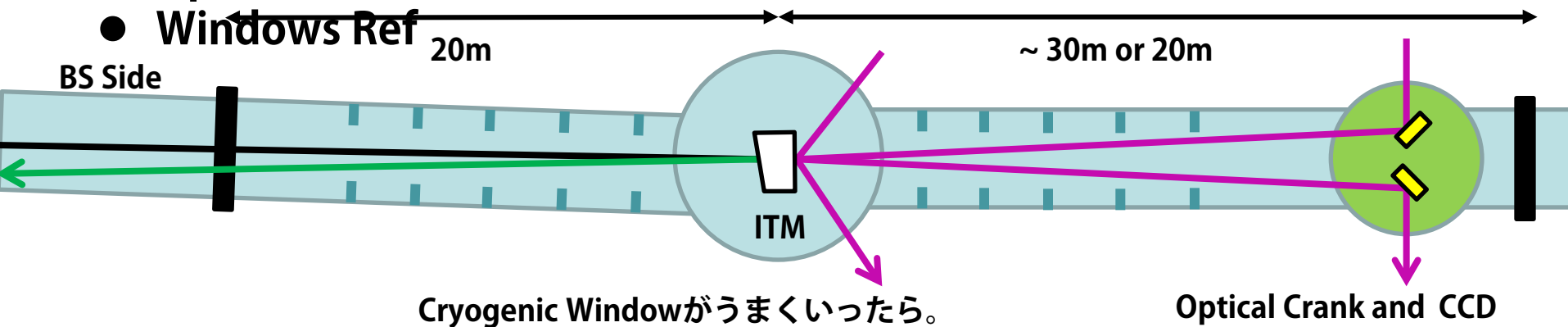

ITM parameters

MIF_Design_Aso20110228

Parameter Name	Value	Comments
HR Reflectivity@1064 nm	99.6±0.01%	Power reflectivity
HR Reflectivity Mismatch @1064 nm	<0.05%	$ R_{ITMX} - R_{ITMY} $
HR Reflectivity@532 nm	80±10%	ITM reflectivity must be smaller than ETM
HR loss@1064 nm	<45 ppm	Including diffraction and absorption
HR loss@532 nm	<1%	Including diffraction and absorption
AR Reflectivity@1064 nm	200(+100/-0) ppm	
AR Reflectivity@532 nm	<5%	
HR ROC	>500 km	As large as possible
HR ROC Mismatch between ITMX and ITMY	<10 km	
AR ROC	>500 km	As large as possible
AR Wedge Angle	0.2±0.002 deg	

Table 1.1: Input Test Mass Requirements

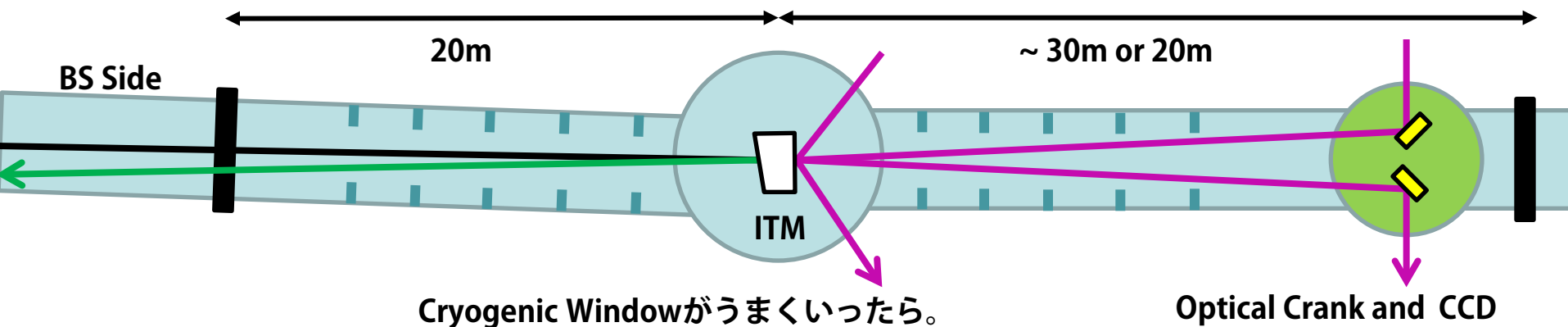

ETM

① ETM

- (ETM center or ETM HR Center) = Tank Center ??
- ETMにウェッジ必要では？ウェッジを考慮したビーム透過方向
(→ Radiation Shield Ductは斜めにつける。斜めでない場合は、バッフル穴の位置に注意。)

② AOS around ETM

- GIM for ETM AR Refs to Tra Monitor
(→ Tra側のRadiation Shieldの切れ込みの指示が必要 ?)
- Optical Crank and CCD monitor Tank from Arm Side
(iLCGTでのTypeCタンクを流用できるか？。高さは不要。)
- Windows Ref

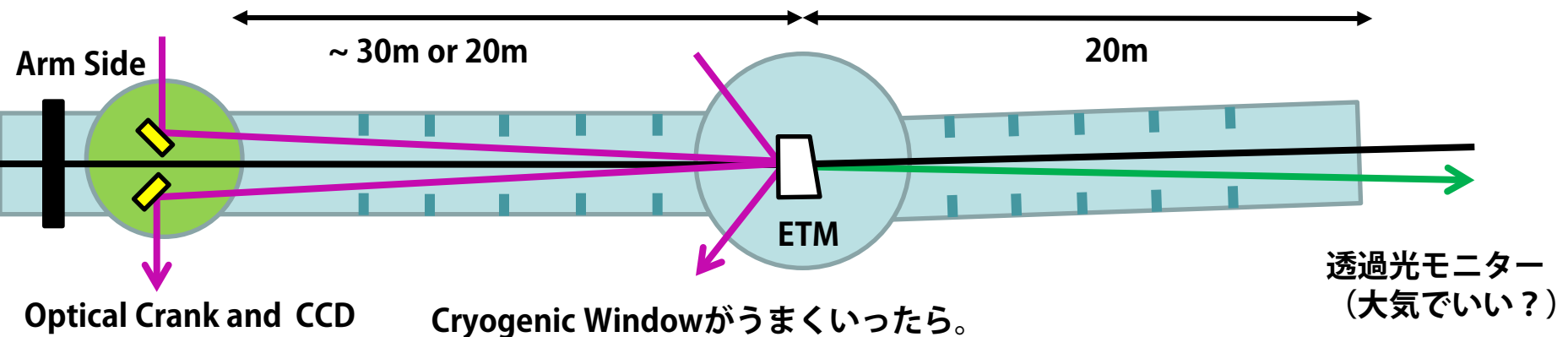

ETM Parameters

MIF_Design_Aso20110228

Parameter Name	Value	Comments
HR Reflectivity@1064 nm	>99.9945%	Power reflectivity
HR Transmissivity@1064 nm	>1 ppm	
HR Reflectivity@532 nm	80±10%	ETM reflectivity must be larger than ITM
HR loss@1064 nm	<45 ppm	Including diffraction and absorption
HR loss@532 nm	<1%	Including diffraction and absorption
AR Reflectivity@1064 nm	<1000 ppm	
AR Reflectivity@532 nm	No requirement	
HR ROC	7000±100 m	
HR ROC Mismatch between ITMX and ITMY	<7 m	
AR ROC	>100 km	As large as possible
AR Wedge Angle	0 deg	

Table 1.2: End Test Mass Requirements

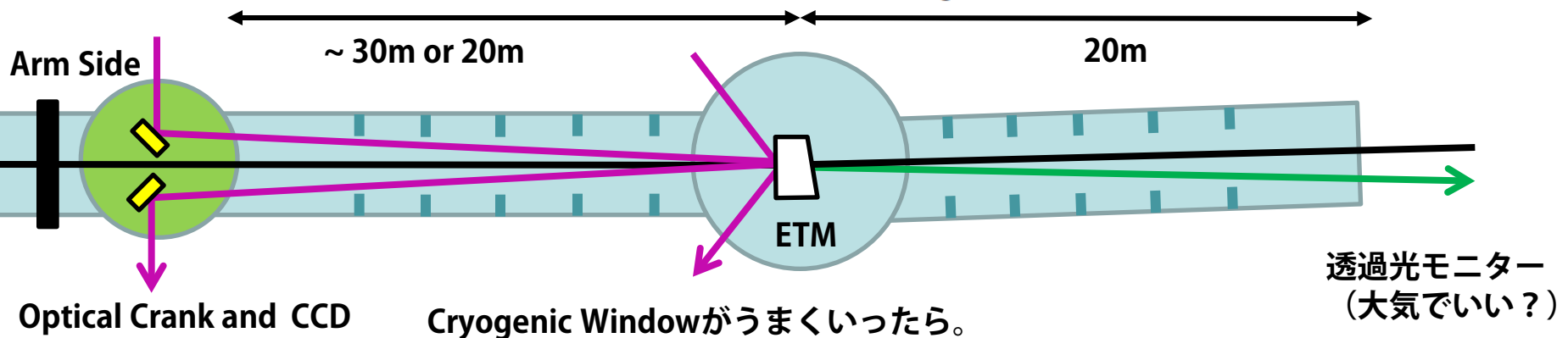

Cryogenic Windowがうまくいったら。

2011年6月16日

SRC 光軸

① SR2, SR1, SRM

- 共振器長 (←FP Cavity, ROC許容誤差, BS-ITM長, 変調周波数)
- ビーム径 (←ダメージ閾値、一瞬でも全然問題ない?)
- 入射角度 (←要求ビーム真円度, 高次モードカップル)
- 位置 (←ITMウエッジ角, BSのウエッジ角度, 鏡の厚み)
- 平行ビーム間隔 (0.629度だとPR1, PR2間隔が~26cm)

② AOS around SR Cavity

- GIM for ETM AR Refs from SR2, SR1, SRM
- Windows Ref
- Green Locking Laser Introduction

