

One starts with an empty cavern. The green support is mounted first on its rails. Using the overhead crane, one by one the vacuum spools are set on temporary supports, the next spool is brought in, and bolted on the preceding one, then the tow are lowered one step and the last is brought in an assembled.

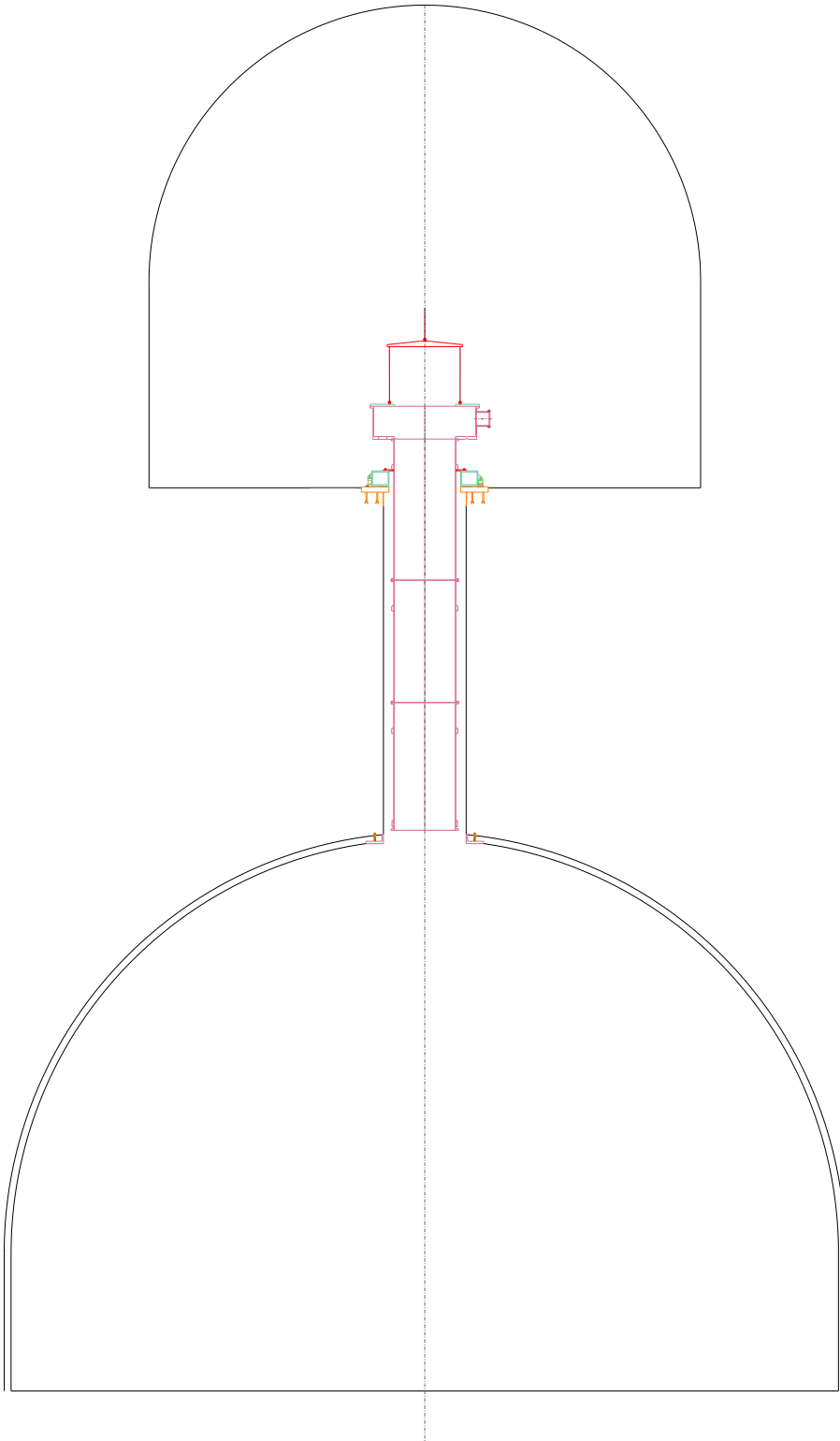

Then the bath tab is brought in and mounted on the top spool
Then the assemble is lowered on its stand.

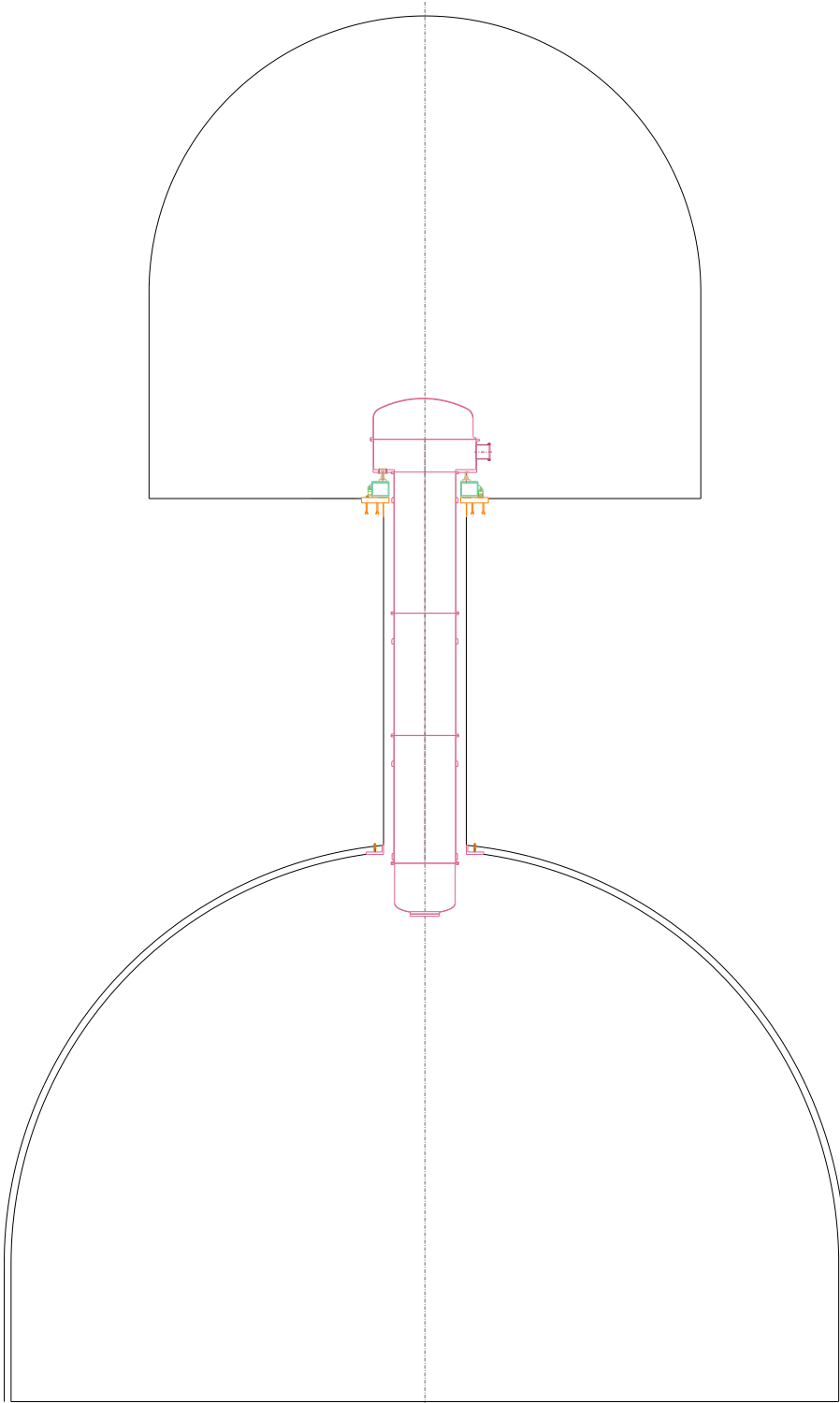

The assembly is closed and UHV tested for leaks, then the top and bottom caps are removed again.

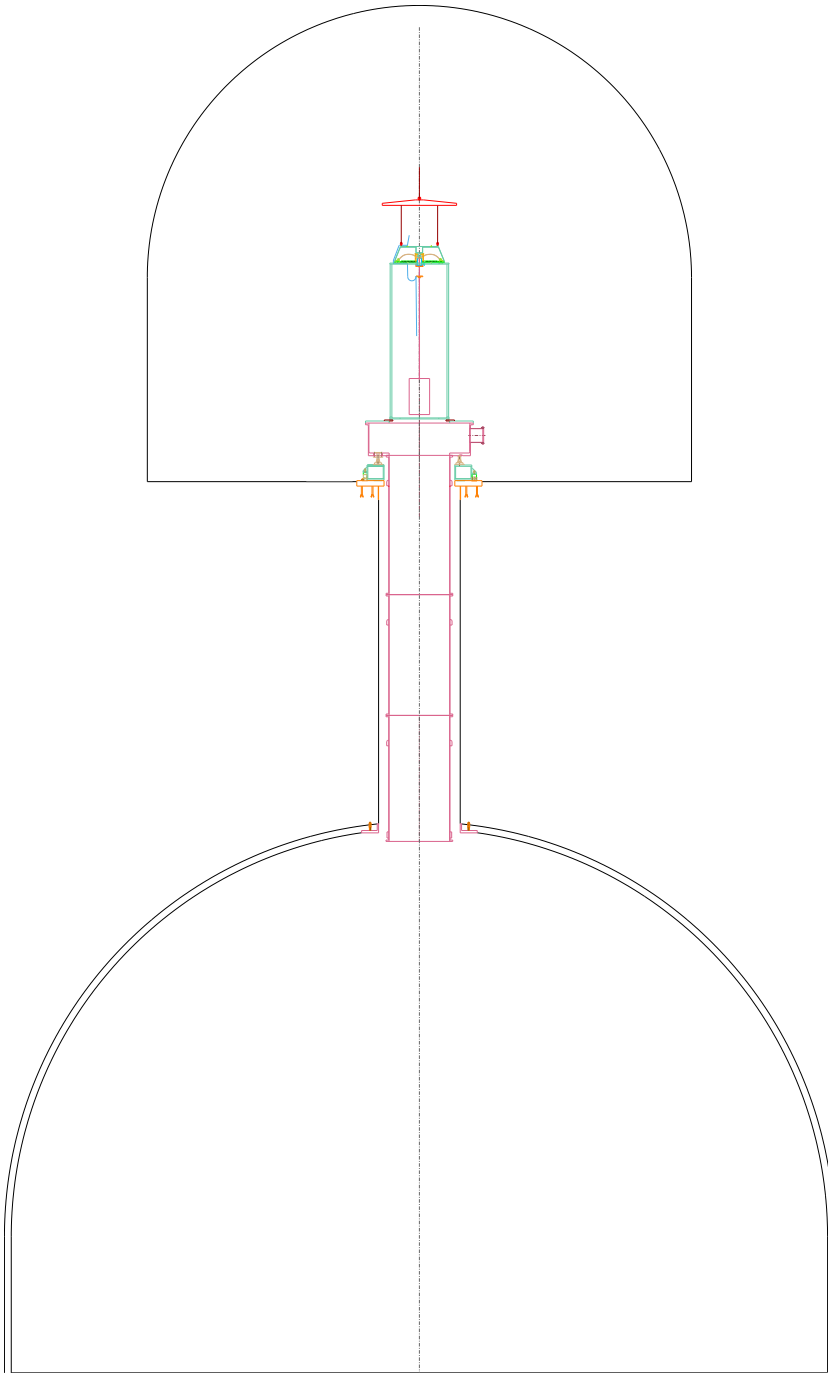

The 300 kg ballast mass is brought in over a temporary safety disk, a temporary safety harness is built, filter number 3 is craned in, sat over the safety harness, connected to the ballast mass and cabling is done between filter 3 and its lower spider. The 300 kg mass is adjusted to filter 3. Then the functionality of filter 3 is checked (vertical oscillation frequency and damping constants) using LVDT and actuator.

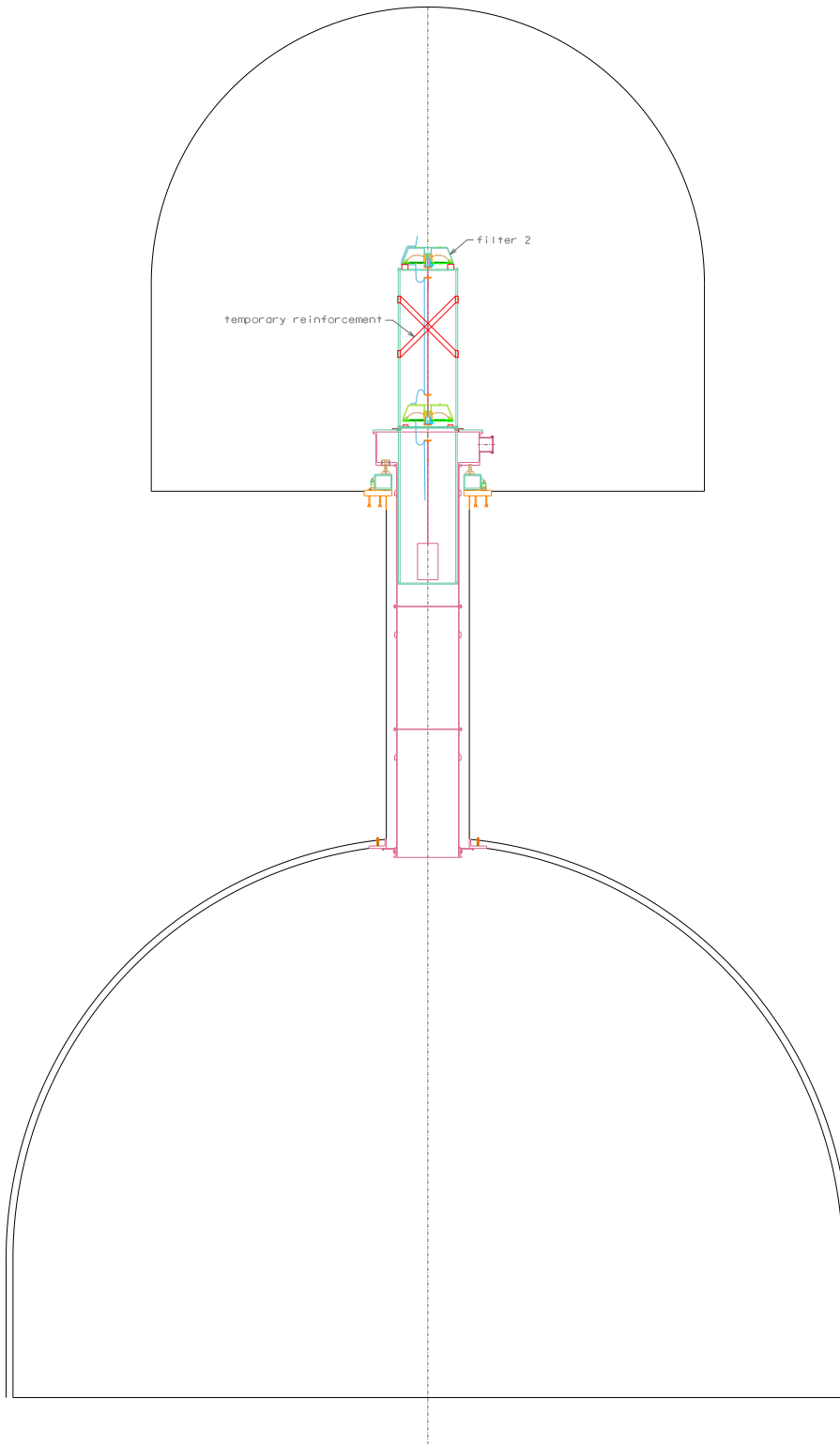

At this stage the safety structure of filter 2 is mounted and the filter mounted over it. Filter 3 is attached and cabled. The ballast mass of filter 3 is adjusted. The functionality of filter 2 and 3 are checked (vertical oscillation frequency and damping constants) using LVDT and actuator, as well as the tilt frequency of filter 3.

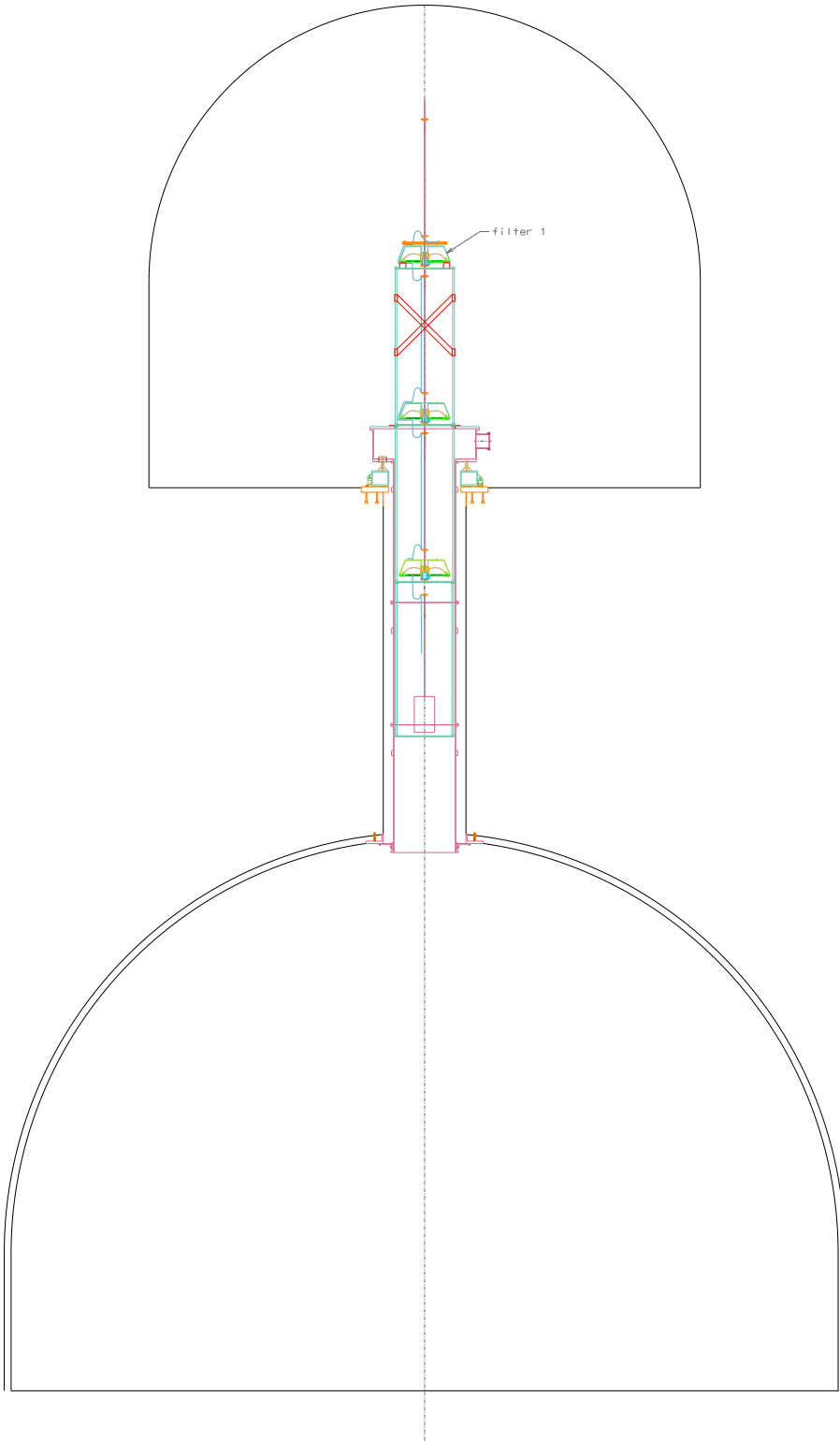

The same testing sequence is repeated for filter 1.

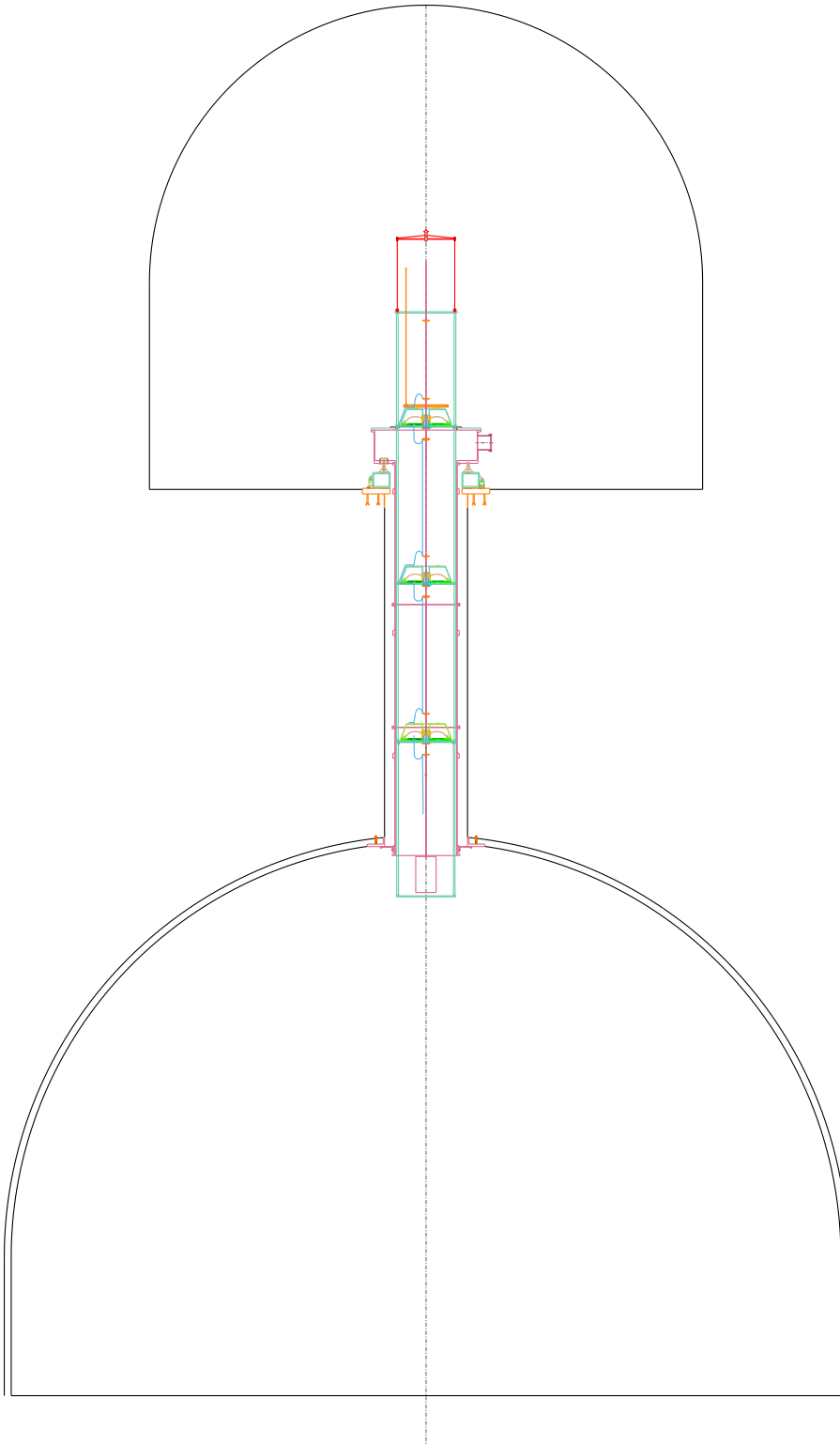

The safety structure between the Top filter and filter 3 is assembled, as well as the suspension wire of filter 3, electrical wiring, and its Eddy current damping ring.

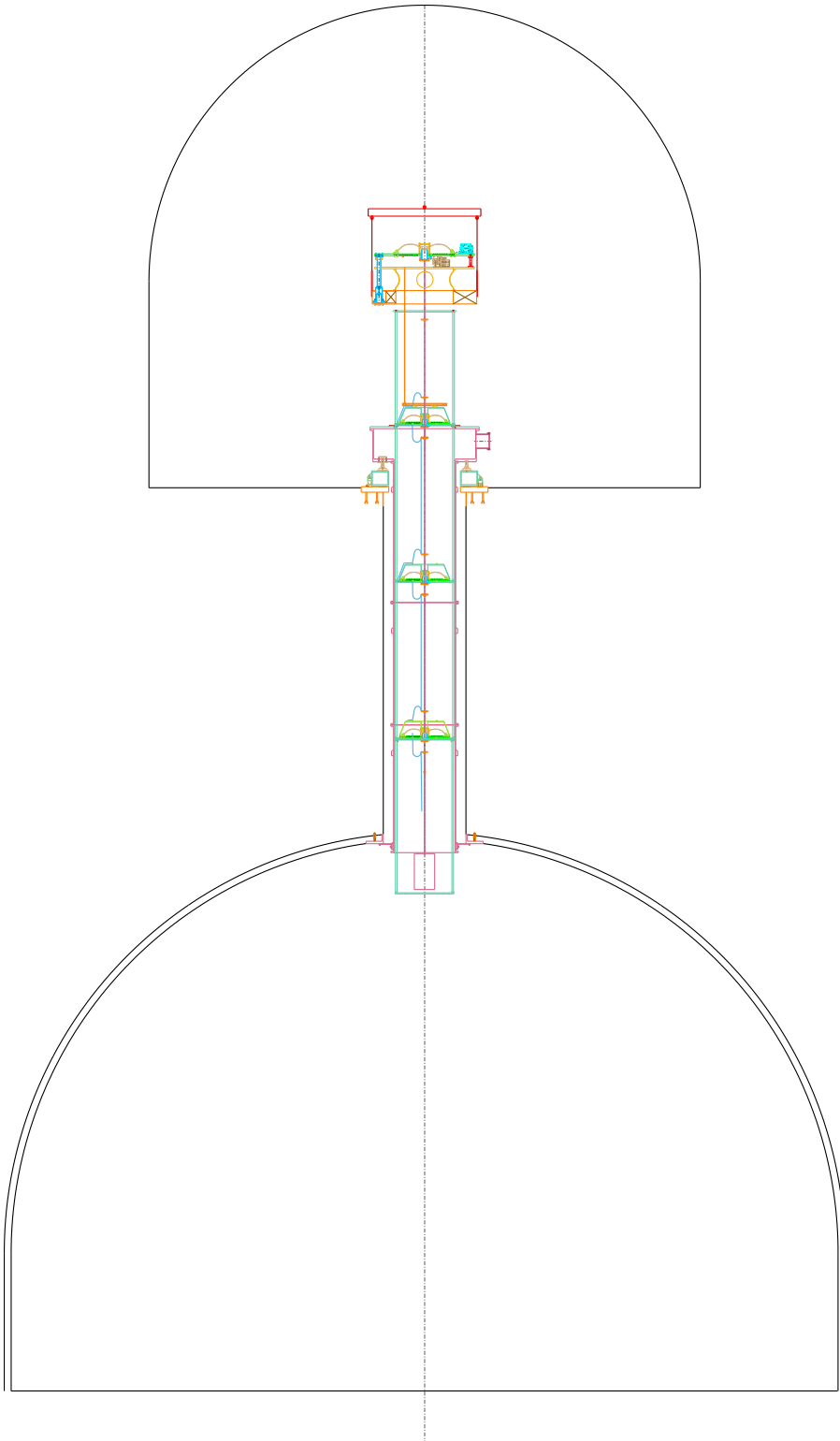

The top filter is brought in, attached to its payload, its functionalities tested, then it is removed.

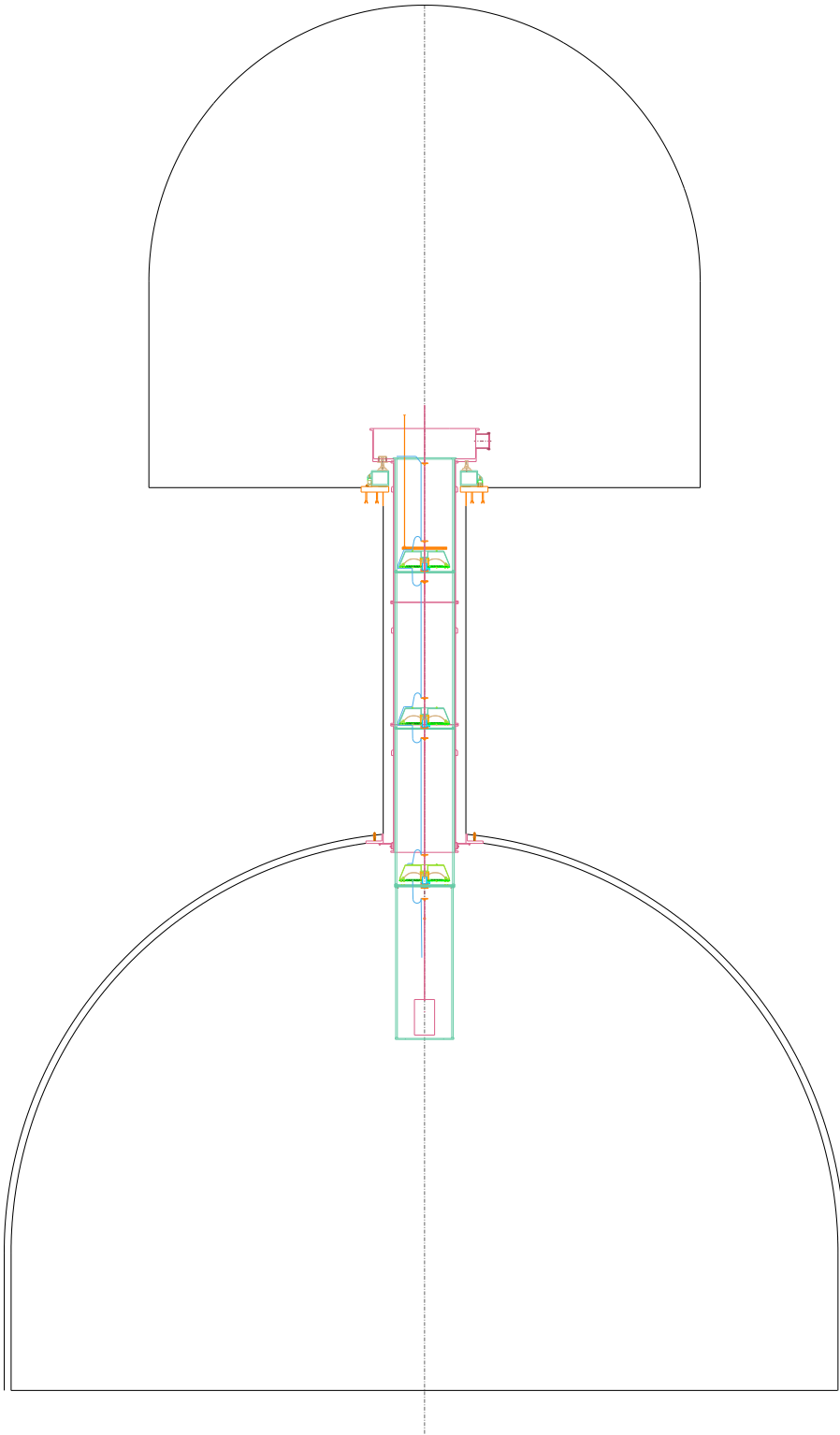

The structure containing filter 1 to 3 is then lowered in place and secured.

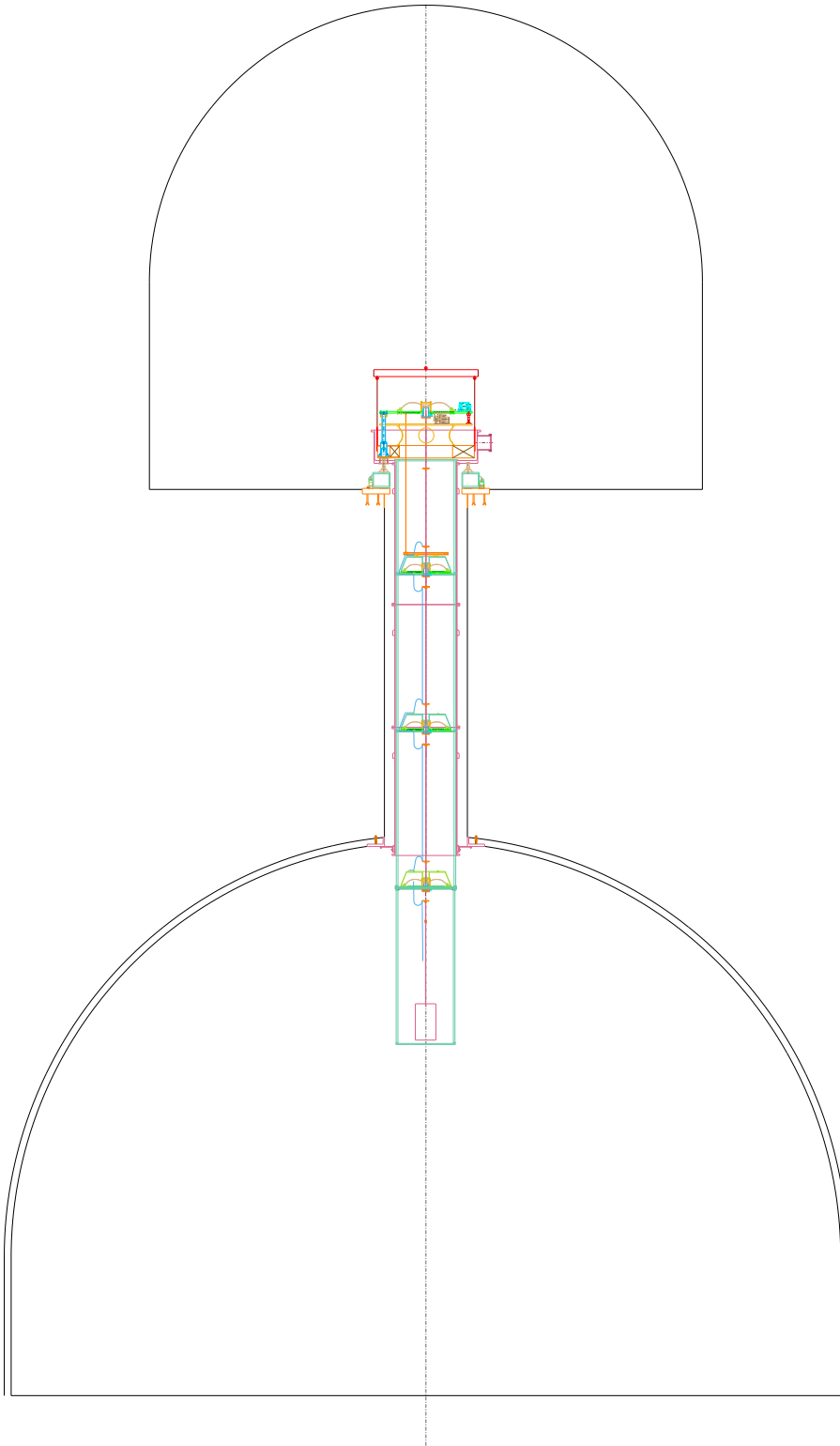

The unit Top filter and Inverted Pendulum is lowered in place, but is still disconnected from filter 1.

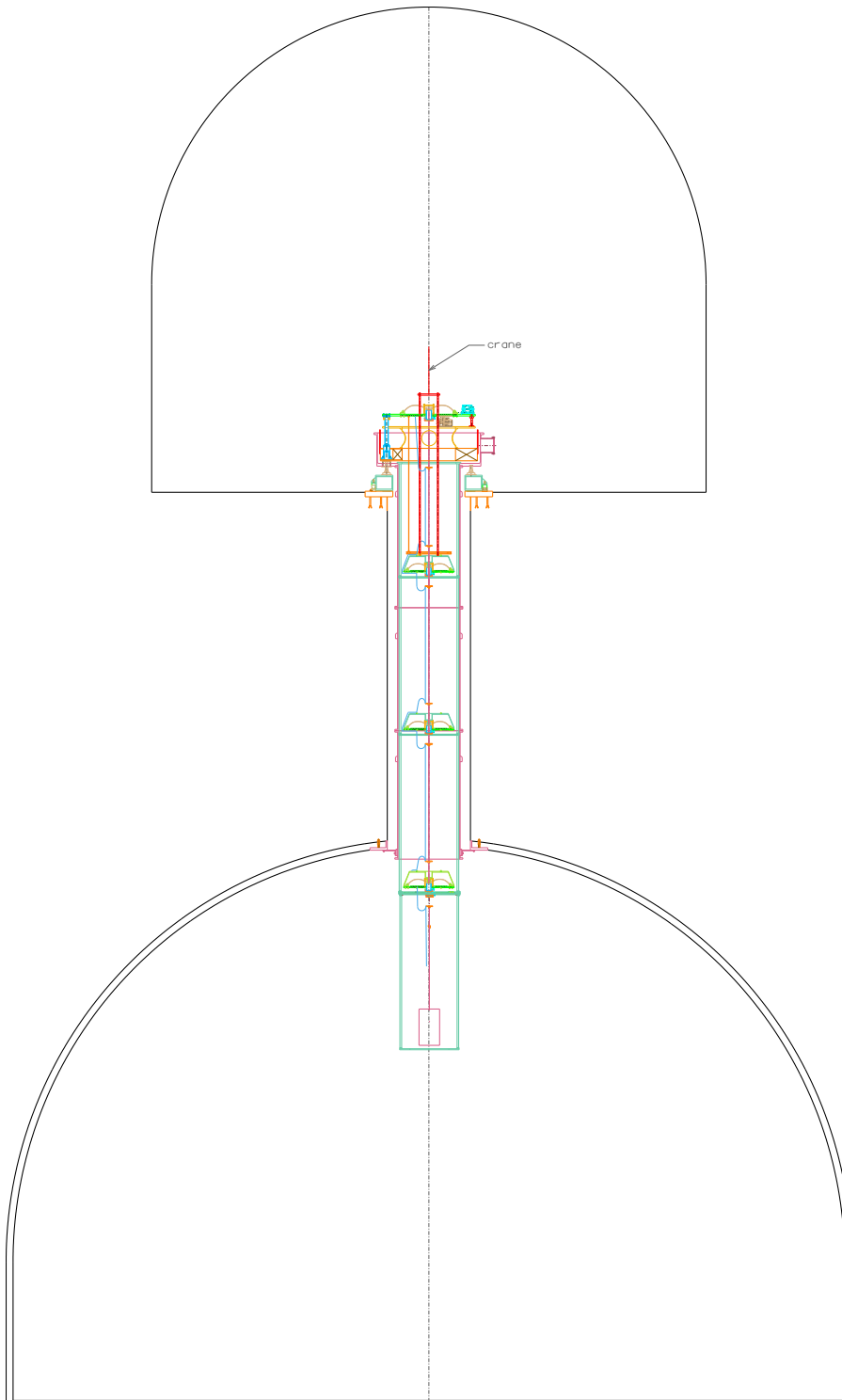

Special lifting rods are inserted through holes into the top filter, are screwed into the roof of filter 1, and used to lift it, so that its wires can be attached to filter zero. The functionalities of all filters are re-checked.

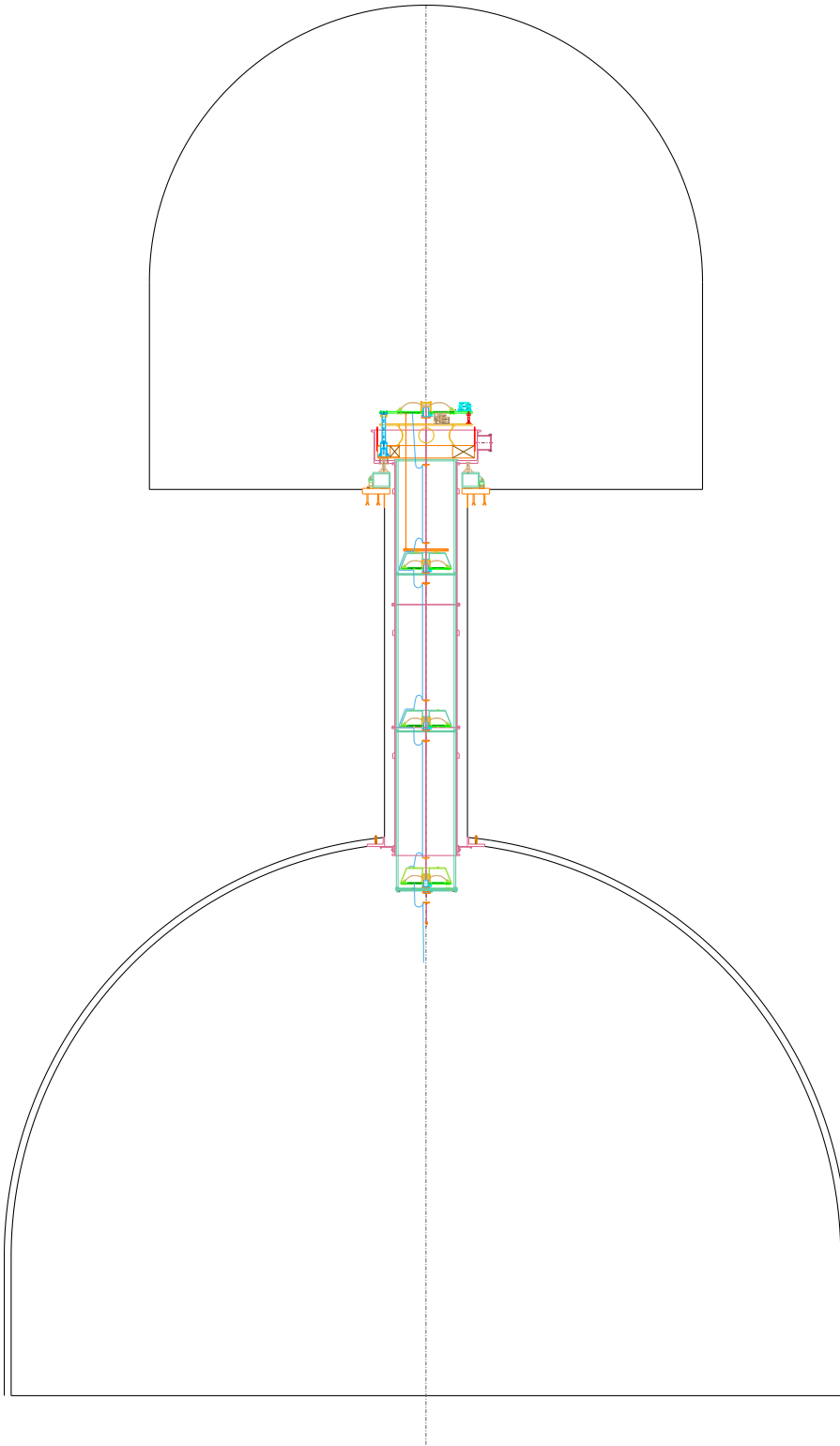

Then the 300 kg payload and its temporary safety structure are removed and the suspension wire is disconnected at the wire junction box. The system is ready for installation of the payload.

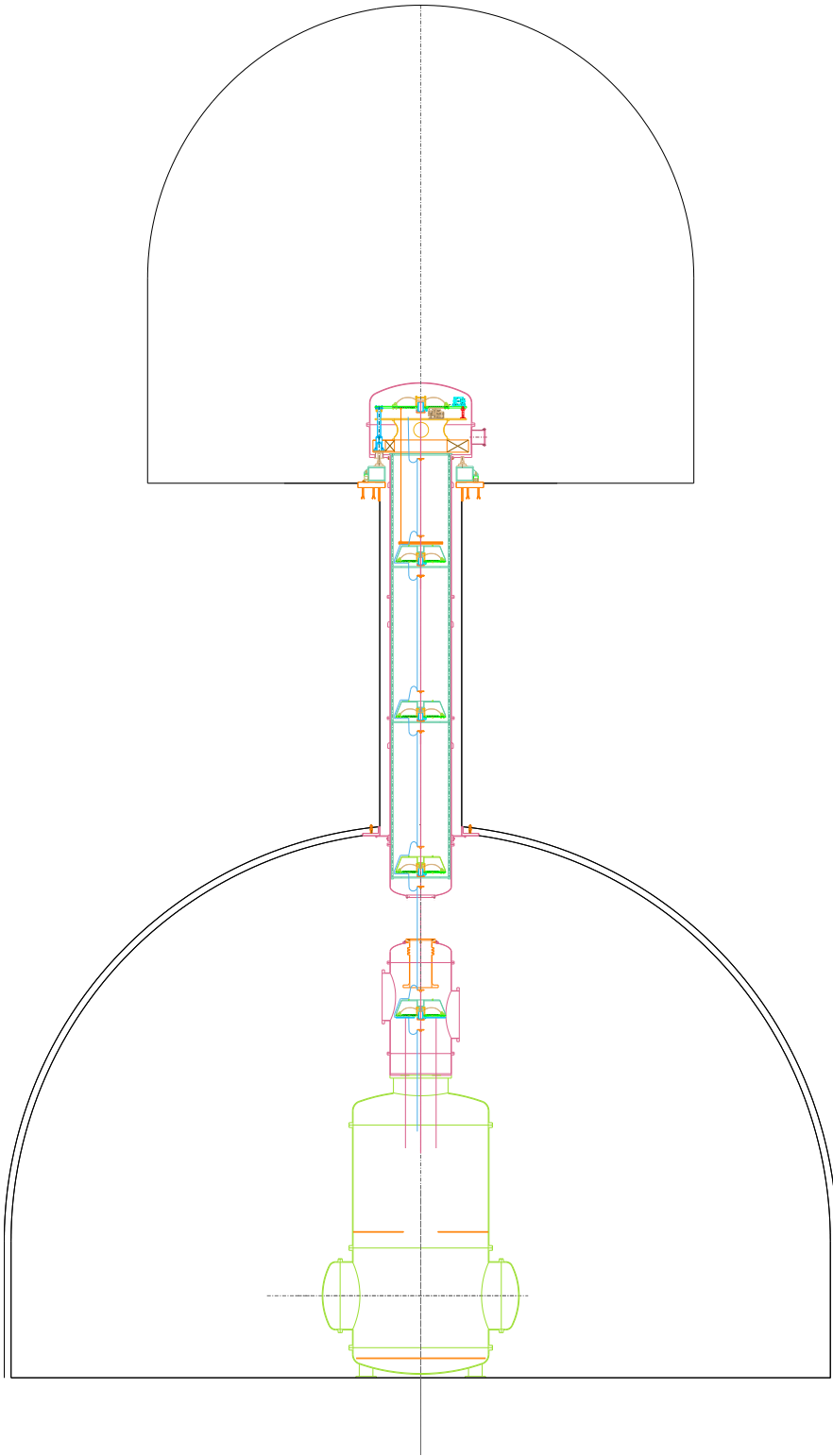

The vacuum chambers are positioned (note only the top, pink, part needs to be removed to insert the SAS chain). Filter 4 is inserted on a stretcher, connected at the junction box and electrically wired. Then the vacuum neck above is closed.

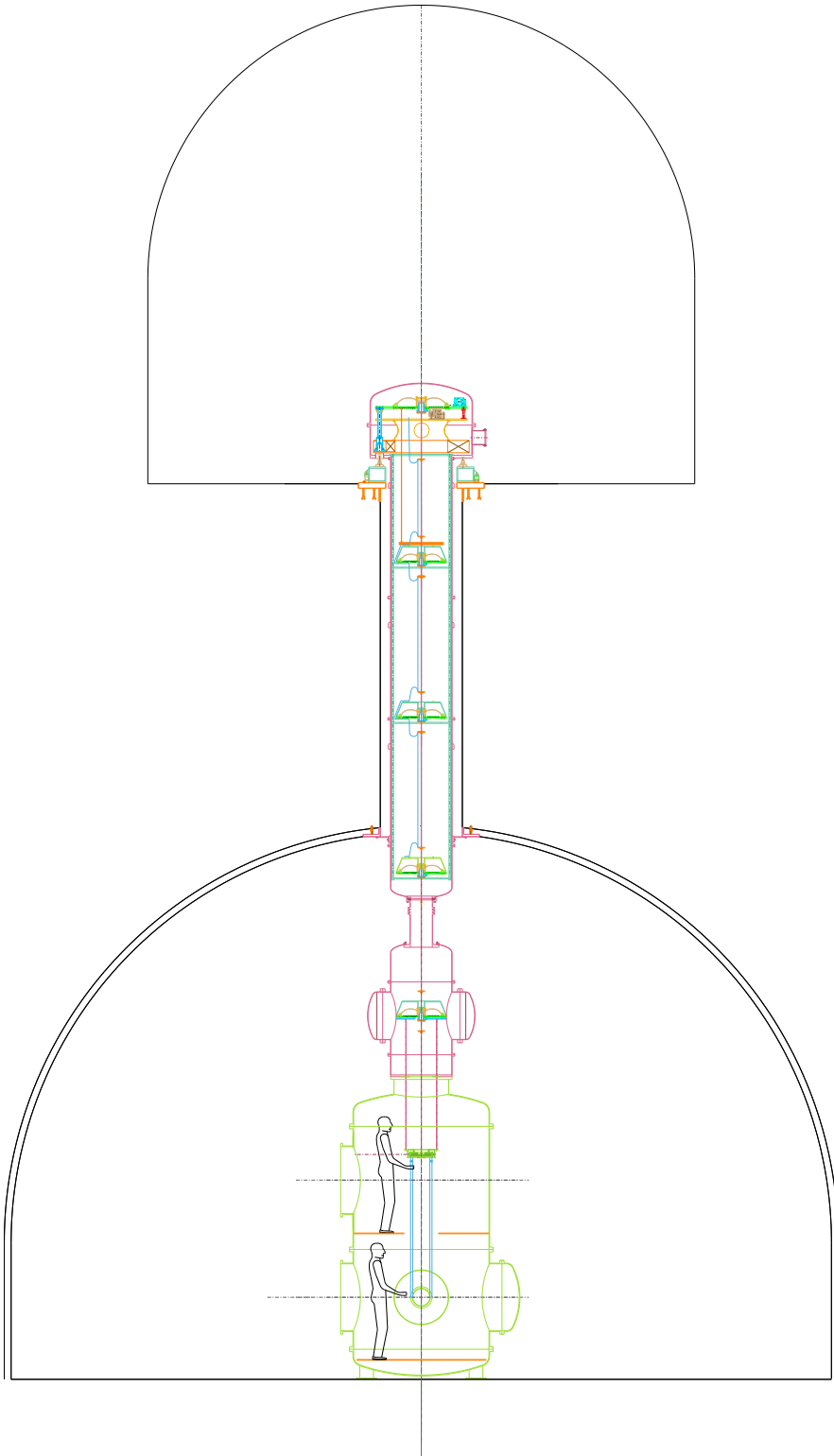

Finally the intermediate mass and the mirror are inserted and suspended.