

(Current) Summary of LCGT Spacial Mode Design task

Conceptual design is almost finished.

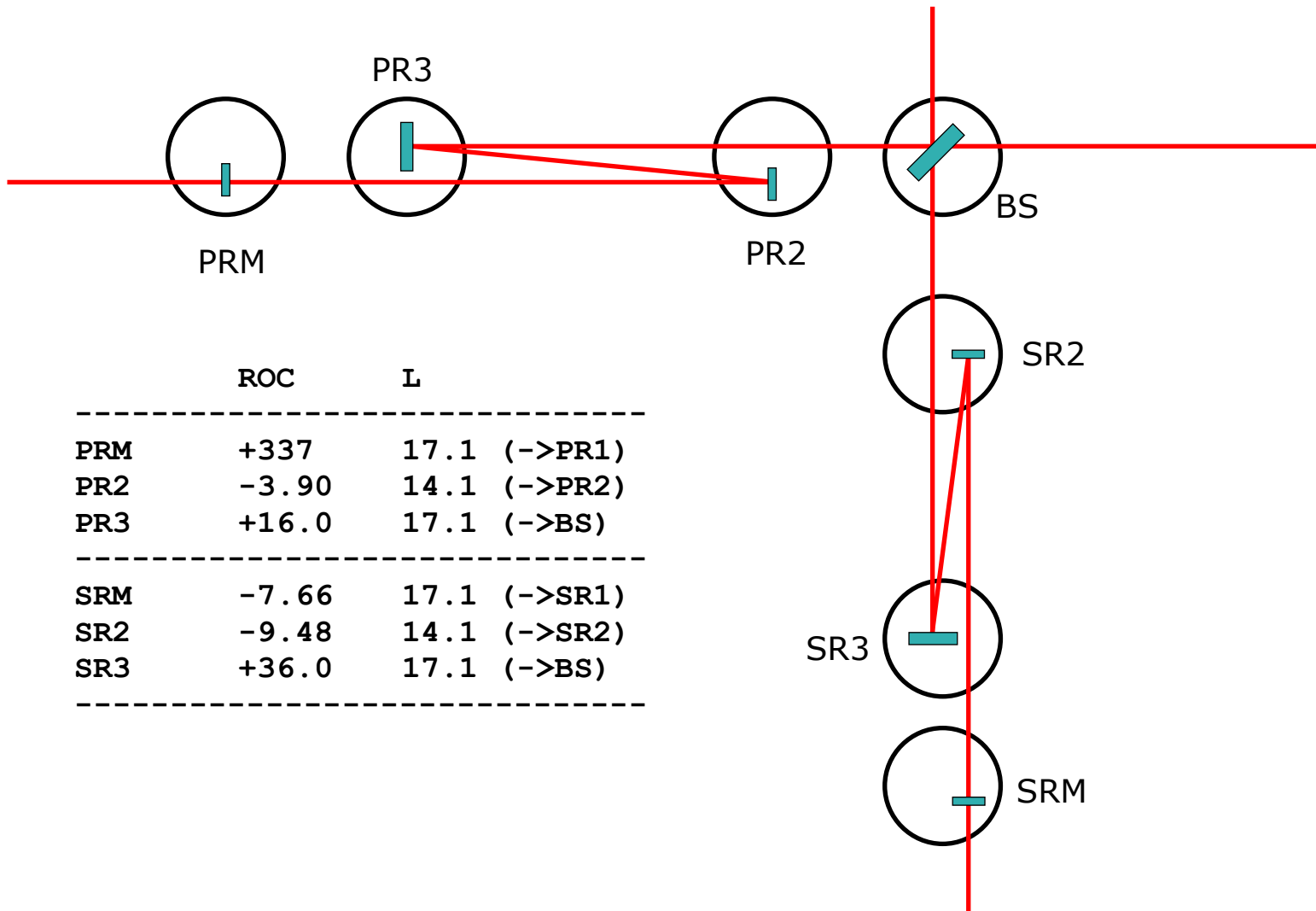

	ROC	L	
PRM	+337	17.1	(->PR1)
PR2	-3.90	14.1	(->PR2)
PR3	+16.0	17.1	(->BS)
SRM	-7.66	17.1	(->SR1)
SR2	-9.48	14.1	(->SR2)
SR3	+36.0	17.1	(->BS)

(Current) Summary of LCGT Spacial Mode Design task

The key-point to install the folded telescope is **fine-adjustment of the telescope length.**

Even if lens mirror has a ROC accuracy of 0.5%, the lens should be relocated within 0.16 m with an accuracy of 2 mm.

It strongly depends on design or capability of the vibration attenuator. Careful discussions with the related groups are needed.

(Current) Summary of LCGT Spacial Mode Design task

Toward the detailed designs the followings should be considered.

* Is astigmatism cancelation design adopted or not?

--> There is no need if incident angles at lens optics are 1 degree.

* Is a tank separation between BS and PR1 enough?

--> Detailed designs of optical layout including vacuum tank port arrangements are needed. Maybe the tank separation of 3 meter is too closed.

* Because lens combinations are strongly related to the matching telescopes between the 2nd mode cleaner and PRM or between SRM and output mode cleaner, there is necessary to fix the telescope or mode cleaner designs.

* As an arm cavity design, is negative-g design adopted?

--> To decide it, calculation and design of alignment sensing and control is needed.

(1) モードを狂わす大きさは大ざっぱにどの位なのか。

1.1) 研磨（曲率半径）の精度

1% を通常精度とし、特注品でも **0.5%** と仮定。

1.2) 冷却に因る表面形状の変化

0.05% 以下

1.3) 熱レンズが多少なりともあるのか

By using MIST it will be evaluated.

1.4) 鏡の基材の一様性

1.5) LCGT 特有の問題点はないか